

This is the peer reviewed version of the following article:

Dv/Dt Filtering Techniques for Electric Drives: Review and Challenges / Pastura, Marco; Nuzzo, Stefano; Kohler, Mario; Barater, Davide. - (2019), pp. 7088-7093. (IECON 2019 - 45th Annual Conference of the IEEE Industrial Electronics Society Lisbon, Portugal, Portugal 14-17 Oct. 2019) [10.1109/IECON.2019.8926663].

IEEE

Terms of use:

The terms and conditions for the reuse of this version of the manuscript are specified in the publishing policy. For all terms of use and more information see the publisher's website.

05/05/2026 16:29

(Article begins on next page)

Dv/Dt Filtering Techniques for Electric Drives: Review and Challenges

Marco Pastura
Dept. of Engineering Enzo Ferrari
University of Modena and Reggio
Modena, Italy
marco.pastura@unimore.it

Mario Kohler
Dept. of Electrical Drives & Hardware
Liebherr-Aerospace Lindenberg GmbH
Lindenberg, Germany
mario.kohler@liebherr.com

Stefano Nuzzo
Dept. of Engineering Enzo Ferrari
University of Modena and Reggio
Modena, Italy
stefano.nuzzo@unimore.it

Davide Barater
Dept. of Engineering Enzo Ferrari
University of Modena and Reggio
Modena, Italy
davide.barater@unimore.it

Abstract— The use of wide band gap devices in power converters is becoming more and more popular since they enable operations at higher switching frequencies, voltages and temperatures compared to traditional power semiconductors, while also improving the efficiency. However, in electric drives, they also tend to increase voltage overshoots at motor terminals and to produce uneven voltage distributions across stator windings, due to their high rate of voltage change over time (dv/dt). In order to mitigate these issues, passive filters can be employed. The aim of this paper is to give an overview of possible solutions based on passive filters, analyzing the main advantages and drawbacks. A comprehensive, qualitative comparative study is carried out taking into account common mode currents reduction, power losses, costs, dimensions and reliability.

Keywords—dv/dt filter, Wide band gap devices, LCR filter, RC filter, LR filter, Common mode transformer, Overshoot reduction, Clamp Diodes, Filter configurations, Reliability, Costs

I. INTRODUCTION

The need for more performing and fast switching electronic devices has led in the last years to the development of wide band gap (WBG) semi-conductor technologies such as Silicon Carbide (SiC) and Gallium Nitride (GaN). WBG devices can operate with less commutation losses and higher switching frequencies than traditional insulated-gate bipolar transistors (IGBTs). This allows the use of more efficient control systems, based on current and/or voltage feedback. The operation at higher carrier frequencies in pulse width modulation (PWM) based drives reduces the harmonic content at lower frequencies, with ensuing benefits in terms of current and torque ripples. High-frequency operations also enable the use of more compact sine or dv/dt filters [1]. In addition, thanks to their higher breakdown voltage [2], they are also more suitable for medium voltage operation. In the case of GaN devices, free wheeling diodes can be avoided since GaN switches are bi-directional [1], [2]. However, WBG semi-conductors present also some drawbacks. They are characterised by significantly short rise times resulting in high voltage gradients (dv/dt), which may lead to significant voltage overshoot at motor terminals [3]. In fact, when the voltage rise time t_r at the inverter output is at least half or less the traveling voltage pulse propagation time t_p [3], [4], a full reflection occurs. Therefore, when $t_r < 2t_p$, the voltage V_m at

motor terminals can be expressed by (1), where V_{dc} is the DC-link voltage and Γ the reflection coefficient.

$$V_m = V_{dc}(1 + \Gamma) \quad (1)$$

The maximum theoretical value of Γ is 1, so the theoretical limit of the voltage peak is 2 p.u. However, according to [3], the voltage peak at motor terminals can result higher than this limit when an additional pulse is applied before the transient overshoot is sufficiently damped. In [5]-[7], it is claimed that a full reflection (hence doubling the motor terminal voltage) can occur when $t_r < 3t_p$. However, assuming that the transient is fully damped, a critical rise time (minimum limit for rise time) equal to $2t_p$ can be hypothesised. This assumption can be considered reasonable when the time between two pulses is at least 3τ [3], with τ defined as in (2):

$$\tau = 2 \frac{l_c}{r_{hf}} \quad (2)$$

In (2), r_{hf} is the per-meter high-frequency cable resistance and l_c is the per-meter cable inductance. Another major challenge of WBG devices is related to the dv/dt itself. High dv/dt can trigger a non-uniform voltage distribution across winding turns [8]. Uneven voltage distributions and voltage overshoots during switching commutations shorten the motor insulation life, thus increasing the possibility for premature failures. The high switching frequencies also accentuate the common mode (CM) voltages and currents, which tend to flow in the parasitic capacitances seen as paths featuring small impedances. A number of solutions to the above challenges have been proposed. Multi-level inverters [9]-[11] permit to reduce voltage overshoots and improve the voltage distribution within windings, while keeping the dv/dt unaltered. However, for medium voltage applications, a dv/dt filter is always recommended according to [11], but the use of such multi-level converters allows to limit the filter size. A proper design of dv/dt filters can result in reduced CM leakage currents and lower losses compared to sine filters [12].

This paper presents a general overview of the main filtering options employed to reduce both voltage overshoots and dv/dt, with a glance also to the reduction of CM voltages. Different filter topologies are first described, with focus on their placement, with respect to the inverter and the motor, and on the components they are made of. Benefits and drawbacks

are also summarised for all of the reported topologies. Manufacturing aspects are then detailed, considering the cost saving as a main objective. A comprehensive comparison between the different filters concludes the work.

II. FILTERS AT MOTOR TERMINALS

Reflected waves and ensuing voltage overshoots are caused by the mismatch between surge impedance of the cable and motor impedance. Filters placed at motor terminals are designed in such a way to match the cable surge impedance Z_c , so that no reflection occurs. Their design is relatively simple and based on the fact that they have to be characterised by an impedance slightly smaller than that of the motor. Hence, there is no need of using many passive components. These filters can be made of only by parallel star-connected resistors or RC networks [13], but an RLC filter is still a viable solution. The design is based on (3), where Z_f is the filter impedance and c_c is the per-meter cable capacitance. For example, if an RC filter was used (see Fig.1), Z_f can be calculated as in (4), where R_f and C_f are the resistance and the capacitance of the filter, respectively, and ω is the angular frequency. R_f needs to be as in (5), where L_c is the equivalent lumped inductance of the cable.

$$Z_c = \sqrt{\frac{l_c}{c_c}} \cong Z_f \quad (3)$$

$$Z_f = \sqrt{R_f^2 + \frac{1}{j\omega C_f^2}} \quad (4)$$

$$R_f > 2 \sqrt{\frac{L_c}{C_f}} \quad (5)$$

Equation (5) is used to obtain an overdamped system, so that resonance caused by the filter becomes quite negligible. All of the filters located at motor terminals with the aim of matching cable surge impedance and motor impedance should be designed according to (3).

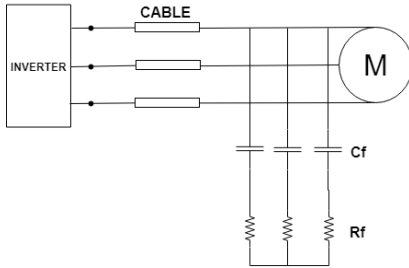

Fig. 1. RC filter at motor terminals.

III. FILTERS AT INVERTER OUTPUT

This section deals with the description of some filter topologies implemented at the inverter output terminals.

A. RLC filters

There are many types of RLC based filters which are usually put at the inverter output. These filters aim at reducing the dv/dt , thus having a positive effect also on the voltage overshoot. In fact, according to the definition of rise time provided in (6), reduced dv/dt means higher voltage rise time.

$$t_r = \frac{0.9V_{max} - 0.1V_{max}}{dv/dt} \quad (6)$$

This type of filters cannot achieve a voltage overshoot reduction comparable with that of an RC filter at motor terminals. However, the dv/dt reduction allows a better voltage distribution across winding turns and a reduction of CM currents. They can be classified in three main categories, according to the type of connection of the passive components.

1) Inductor with an RC series (type 1)

In Fig. 2, the inductors L_f are in series with the inverter terminals, while the group comprising the series of $R_f C_f$ is connected in parallel. However, the design is carried out in a different way. A proper design of a dv/dt RLC filter is a difficult task. Details, guidelines and practical examples are available in [14-16]. Unlike sine filters, dv/dt filters have a resonant frequency above the switching frequency, so resonant effects are not very significant, in particular if the system is overdamped. For this filter, indicated as “type 1”, this hypothesis is true when (7) is verified.

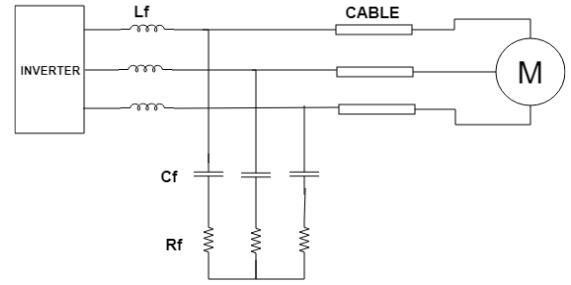

Fig. 2. RLC filter at inverter output (type 1).

$$R_f \geq 2 \sqrt{\frac{L_f}{C_f}} \quad (7)$$

In addition, in a 3-phase system, if the mutual coupling between phases is negligible, the filter can be designed considering only one phase. Therefore, the value of L_f should be kept significantly below the motor transient inductance, so that the drive dynamic performance remains nearly the same.

Focusing on the dv/dt , it can be expressed as in (8), where ω_0 is the resonance pulsation and is equal to $1/\sqrt{L_f C_f}$.

$$\frac{dv}{dt} = \omega_0 V_{DC} \quad (8)$$

Equation (8) indicates that there are infinite combinations to select L_f and C_f . They can be chosen taking in consideration some constraints, such as the minimisation of the voltage drop across the filter inductance. This constraint can be described by (9), where, $x\%$ is the maximum allowed voltage drop percentage, V_b and S_b are the base voltage and power of the system, respectively [16].

$$\omega L < x\% \frac{V_b^2}{S_b} \quad (9)$$

An important aspect relates to the role of the resistors in series with the capacitors. If on one side they are necessary to damp the LC resonance, on the other hand they have the drawback of limiting the currents flowing across the RC blocks, which should be chosen carefully. However, in [17], it is highlighted that, sometimes, in WBG based drives, an LC filter with no resistors could be sufficient since the resonant frequency is far from both the control bandwidth and the switching frequency.

2) Resistor in parallel with inductor (type 2)

This topology, indicated in Fig. 3 as “type 2”, overcomes the drawback of the “type 1” filter relative to the current limitation across the RC group, but its effectiveness is related to the cable length. Long cables with high capacitance can produce elevated reflected voltage waves at the filter, causing high power loss in the resistor [18]. A preliminary design can be based on (8) once the desired dv/dt is targeted, whereas for overdamped systems, the filter parameters have to be selected according to (10).

$$R_f \leq \frac{1}{2} \sqrt{\frac{L_f}{C_f}} \quad (10)$$

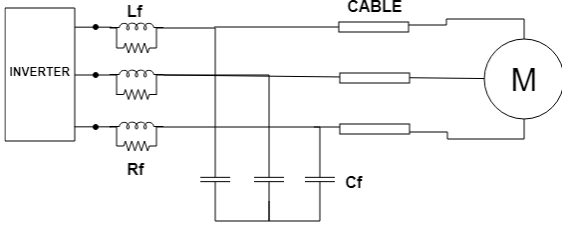

Fig. 3. RLC filter (type 2).

3) RC series in parallel with inductance (type 3)

An innovative topology, reported in Fig. 4, is proposed in [18]. It presents the following advantages:

- The capacitor C_f limits the voltage stress across R_f .
- The capacitor C_f can be used to detect resistor failure. In fact, when R_f gets damaged, it acts as an open circuit and this feature can be used to prevent motor failure. The failure detection method includes also a capacitor voltage monitoring system. In fact, an increase of the voltage across C_f is an indicator that the capacitor is going to fail.

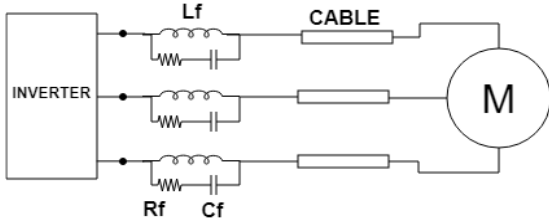

Fig. 4. RLC filter (type 3).

The design presented in [18] complies with the relationships shown in (11) and (12).

$$\tau_{RC} > (t_{don} + t_r + t_f + t_{doff}) \quad (11)$$

$$R_f \leq \frac{\sqrt{L_f + L_c}}{2C_c} \quad (12)$$

In (11), τ_{RC} is the time constant of the RC network, t_{don} and t_{doff} are respectively the turn-on and turn-off delay times, t_f is the falling time, L_c and C_c are the lumped parameters of the cable equivalent circuit.

B. LC clamp filters

A different dv/dt filter topology consists in an LC filter combined with a diode bridge which clamps the voltage to a slightly higher value than V_{dc} . This permits to reduce the

overvoltage. The diode bridge can be located after the capacitors C_f , as illustrated in Fig. 5 [18], or interposed between the inductors and the capacitors [19], [20]. Two damping resistors connect the rectifier to the DC bus terminals. In [19] and [20], even the star-connected capacitors are connected to the bus terminal through damping resistors. Equations (8) and (9) are valid also for a preliminary design of an LC filter followed by a diode bridge rectifier (Fig. 5). The main challenge of this topology is related to the currents flowing back to the DC bus through the resistors. These currents can be very high, thus potentially producing a significant thermal stress on the resistors themselves. Therefore, to limit the maximum current I_{pk} flowing through the diodes, the filter inductance can be sized using (13).

$$L_f = \frac{V_{dc}}{I_{pk}\omega_o} \quad (13)$$

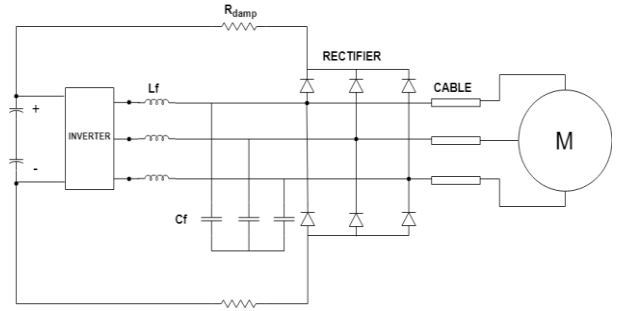

Fig. 5. 3-phase diode rectifier in series with the LC filter.

C. Parallel LR Filter

Another possible filtering layout is presented in Fig. 6 [21]. This filter consists only in a resistor and an inductor connected in parallel to each other. Its main aim is to reduce the overvoltage. The design is relatively simple and based on the cable oscillation frequency f_o , whose expression is given in (14), where l is the cable length. The resistance should be chosen slightly lower than the cable surge impedance. In fact, according to [21], when this condition is verified, the sine of the impedance argument is proportional to the terminal overvoltage. This means that a small argument (typically 5°) needs to be selected. Then, the filter inductance can be calculated as in (15), where φ is just the aforementioned argument. This type of filter can be a very interesting solution when the main purpose is to mitigate overvoltage phenomena and the motor terminals are not accessible.

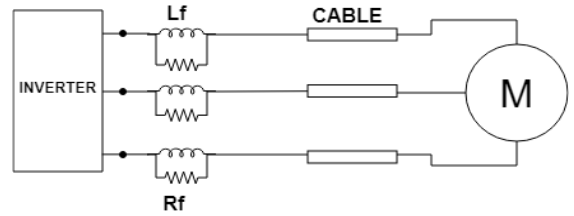

Fig. 6. Parallel LR filter.

$$f_o = \frac{1}{4l\sqrt{L_c C_c}} \quad (14)$$

$$L_f = \frac{\tan(\frac{\alpha}{2} - \varphi) R_f}{2\pi f_o} \quad (15)$$

D. Hybrid filters

In [22], a hybrid solution between inverter output filters and motor terminal filters is proposed. This consists of a series inductance at the inverter output and an RC filter at motor terminals, aiming to combine both dv/dt reduction (through the reactor) and overshoot reduction (thanks to the RC filter).

Promising results have been shown in terms of voltage overshoot and dv/dt reductions, however the study has investigated applications featuring low switching frequency and dv/dt . Therefore, there is room for further investigating such hybrid topology, especially when higher switching frequencies and dv/dt are in place.

Another hybrid solution is reported in [23], where an RL parallel filter (such as that shown in Fig. 3) is located at the inverter output, while the capacitors are positioned at the motor terminals. As well as the solution proposed by [22], this topology achieves both dv/dt and overshoot reductions and is characterised by lower losses than both a traditional RLC filter (Fig. 2) and an RC filter (at motor terminals), assuming the same overshoot.

E. Considerations on CM voltages and currents

In the previous sections, focus was given to the reduction of differential mode dv/dt . However, both CM dv/dt and rms value can be reduced. According to [24], RLC filters put at inverter output can reduce CM currents up to 70% if the neutral point of the filter is connected to the neutral point of the DC bus bar. Improved results can be obtained with a CM transformer (CMT), such as that reported in Fig. 7.

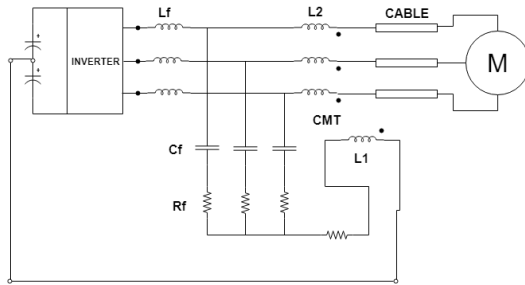

Fig. 7. RLC filter and CMT in series. The RC network neutral point is connected to the DC bus neutral point.

This solution is discussed in [24] and [25]. It is shown that the CMT does not affect the differential mode dv/dt provided by the RLC filter, thus their design can be carried out independently. To maximize the filter performance, the mutual coupling in the CMT has to be as high as possible. With a value of $k=M/\sqrt{L_1 L_2} \approx 0.9$ (where L_1 and L_2 are the self-inductances of the CMT windings and M is their mutual inductance), a $\approx 80\%$ reduction of the common mode rms voltage has been achieved in [24]. Similar results are obtained in [26] by using a CM inductor. The operating principle is the same, i.e. to produce a low differential mode impedance and a high CM impedance before the motor.

F. Considerations on manufacturing

A number of possible circuitual solutions, aimed at mitigating challenges such as voltage short rise time and CM voltage and current, have been described in this section. Despite the importance of finding ever-innovative and effective configurations, an important aspect to consider relates to the manufacturing of these filters. Often, cost minimisation is one of the main objective. Bulky inductors can be very costly, hence in [27] the parasitic inductance between

power devices and inverter output terminals is exploited. This solution is possible in medium/large power converters where the distance between power devices and inverter output terminals is at least $1m$ long, thus making the stray inductance equal to $\approx 1\mu H$. This results in a dv/dt mitigation at $5\div 10$ $kV/\mu s$, even in converter using SiC semi-conductors. The proposed filter configuration is the RLC “type 1” described in Section III.A.1. This solution achieved losses lower than 0.2% of the converter output power [27]. Another solution is proposed in [28], where capacitance, inductance and resistance are integrated in a single, compact structure, allowing for costs and overall dimensions’ minimisation. The device is composed by a copper bus bar, wound by alternating layers of plastic film and metal foil, which incorporates high magnetic permeable material. This structure has the peculiarity of the coexistence of electric and magnetic fields in the same physical space. Attention should be given to the temperature effects, since the damping function is not provided by an external resistance.

IV. COMPARISON

This section concludes the paper by presenting a comprehensive comparison among the filter topologies. Focus is given to power losses, costs, dimensions, and reliability.

A. Power losses

Power losses are an important key factor in the design of a filter as they impact efficiency and operating temperatures.

Normally, power losses due to the capacitors are negligible with respect to those associated to inductors and resistors. The majority of losses are often attributable to the damping resistors and can be generally summarized as in (16), where I_h indicates the rms value of the h^{th} current harmonic and R_h is the equivalent resistance at the corresponding frequency.

$$P_R = \sum_h R_h I_h^2 \quad (16)$$

At high frequencies (above 400 Hz), skin effect additional losses can become more significant due to the increase of the equivalent resistance. For an RC filter such as that shown in Fig. 1, (16) is accurate enough for power losses computation, while the losses generated within the inductors need to be taken into account when an RLC filter is adopted. The inductance losses can be divided into core losses, dependant on how the inductance is structured, and winding losses, which can be determined in the same way as for the resistors. As underlined in [29] and [30], core losses computation may be difficult, since voltage excitation is not sinusoidal. On the other hand, a first estimation of losses-per-volume and/or losses-per-mass can be evaluated leveraging on the classical Steinmetz equation updated with a waveform coefficient FWC ($\pi/4$ for a square wave with a duty cycle of 0.5), as shown in (17) [29]. In (17), P is the iron loss, k , α and β are frequency dependent parameters, f is the excitation frequency and B the maximum value of the flux density.

$$P = FWC \cdot k \cdot f^\alpha B^\beta \quad (17)$$

The presence of additional components, such as the diode bridge rectifier (Fig. 5) or the CMT (Fig. 7), means higher losses.

TABLE I. COMPARATIVE SUMMARY OF DIFFERENT FILTERS

Filter Topology	dv/dt reduction	Overshoot reduction	CM currents	Reliability	Cost	Losses	Location
RC	low	high	N/A	medium low	low	low	Motor terminals
RL parallel	low	high	N/A	medium	medium low	medium low	Inverter output
RLC 1	high	good	up to 70%*	medium high	variable	low	Inverter output
RLC 2	high	good	up to 70%*	medium high	variable	low	Inverter output
RLC 3	high	good	up to 70%*	high**	variable	low	Inverter output
LC+diode bridge	high	high	N/A	medium low	high	medium low	Inverter output
RLC+CMT	high	good	> 80%	medium high	high	medium low	Inverter output
Hybrid RLC***	high	high	up to 70%*	medium high	variable	low	Inv. out+Mot. Ter

* If filter neutral point is not floating; ** With resistor failure detection circuit; ***Available data are referred only to quite low dv/dt and voltages.

These are associated to the diodes’ parasitic resistance when a diode rectifier is used, whereas CMT losses can be divided again into core and winding losses. Despite the presence of both damping resistors and inductors, RLC filters seem to have a very good efficiency if properly designed, with power losses always below 1% of the output converter power, and often even below 0.2% with a maximum switching frequency of 10 kHz [27],[28]. The LC filter with diode bridge rectifier illustrated in [2] can also achieve low losses (0.3% at 10 kHz). The RC filter has comparable losses with the RLC one, which can be even lowered when the switching frequency is not higher than a few kHz.

B. Cost and dimensions

As mentioned in Section III.F, cost reduction is always an important objective in the filter design process. In aerospace and automotive applications, weight and volume play also an essential role. RC filters at motor terminal or RL filters at inverter output seem very good candidates for weight and volume reductions, however they have limited capabilities in reducing dv/dt. RLC filters overcome this challenge, as proven in [27], where also high efficiency and low costs have been achieved. The solution reported in [27] fits well also for weight reduction, while the configuration proposed in [9] prioritises the volume reduction. An LC filter features costs and weights comparable to RLC layout. Nevertheless, the inclusion of the damping resistors and the diode bridge necessarily increases the overall dimensions. In [31], a cost-based study is carried out. Assuming that the resistors cost is negligible with respect to other components, then RLC and LC filters present similar costs. Film capacitors’ costs can be proportional to the capacitance value and voltage, whereas standard aluminium electrolytic capacitors’ costs are proportional to voltage and stored energy. These concepts can be inferred in (19) and (20), where a , b and c are suitable cost coefficients (further details can be found in [31]), C_r and V_r are the capacitance and voltage rated values.

$$Cost_{film} = a + b_1 V_r + c_1 C_r \tag{19}$$

$$Cost_{ELCO} = b_2 V_r + c_2 C_r V_r^2 \tag{20}$$

C. Reliability

Another important aspect to consider when comparing different filter topologies relates to the reliability. When a

failure in the filter occurs, the motor is exposed to higher voltage gradient stress and overshoot, thus leading to a faster insulator degradation and in turn to a motor lifetime reduction. When a resistor comprised in the filter is damaged, it behaves as an open circuit. This means that RC filters would no longer operate. Contrarily, RLC filters or parallel RL filters would not totally lose their filtering capability. However, with RLC “type 2”, dangerous resonance phenomena may occur, while a “type 3” filter would allow an easy detection of the resistance failure. Hence, the latter topology seems to be the most reliable one, but it comes at the cost of increasing weight, volume and thus overall costs.

A qualitative overall comparative summary among the described passive filters is reported in Table I. The cost of the RLC filters is set to “variable” since the inductance value can vary significantly, depending on the choice and on the objectives during the design. Simulations and more quantitative studies will be presented in future works.

V. CONCLUSION

This paper provides a general overview on the use of passive filters as means to mitigate the main critical challenges associated to WBG-based converters employed in electric drives. The main available filter topologies investigated in previous studies were illustrated, with focus on their location within the electric drive. The positive effects on dv/dt and voltage overshoots at motor terminals were highlighted, since these represent the main critical aspects when WBG switches are employed. In addition, considerations on how to reduce CM voltages and currents by using passive filters were carried out. It was highlighted that the use of filters is often mandatory and that using configurations simpler than RLC filters may be not sufficient. The reduction of the only voltage overshoot obtained with impedance matching does not prevent the non-uniform voltage distribution across winding turns, so a dv/dt reduction is also needed.

Finally, a comparison among all of the investigated filters, taking into account losses, costs, dimensions and reliability, was performed. It was shown that, although cost often is the main design objective, reliability also plays a significant role. It is perceived that the overall drive reliability represents the most challenging aspect to investigate for future research and industrial purposes.

ACKNOWLEDGMENT

RAISE project has received funding from the Clean Sky 2 Joint Undertaking under the European Union's Horizon 2020 research and innovation programme under grant agreement No 785513.



REFERENCES

- [1] K. Shirabe et al., "Advantages of high frequency PWM in AC motor drive applications," 2012 IEEE Energy Conversion Congress and Exposition (ECCE), Raleigh, NC, 2012, pp. 2977-2984.
- [2] K. S. Boutros, R. Chu and B. Hughes, "GaN power electronics for automotive application," 2012 IEEE Energytech, Cleveland, OH, 2012, pp. 1-4.
- [3] G. Skibinski, D. Leggate and R. Kerkmann, "Cable characteristics and their influence on motor over-voltages," Proceedings of APEC 97 - Applied Power Electronics Conference, Atlanta, GA, USA, 1997, pp. 114-121 vol.1.
- [4] G. Pietrini, D. Barater, C. Concari, M. Galea and C. Gerada, "Closed-form approach for predicting overvoltage transients in cable-fed PWM motor drives for MEA," 2016 IEEE Energy Conversion Congress and Exposition (ECCE), Milwaukee, WI, 2016, pp. 1-7. doi: 10.1109/ECCE.2016.7854917.
- [5] J. He, G. Y. Sizov, P. Zhang and N. A. O. Demerdash, "A review of mitigation methods for overvoltage in long-cable-fed PWM AC drives," 2011 IEEE Energy Conversion Congress and Exposition, Phoenix, AZ, 2011, pp. 2160-2166.
- [6] A. von Jouanne and P. N. Enjeti, "Design considerations for an inverter output filter to mitigate the effects of long motor leads in ASD applications," in IEEE Transactions on Industry Applications, vol. 33, no. 5, pp. 1138-1145, Sept.-Oct. 1997.
- [7] M. J. Scott et al., "Reflected wave phenomenon in motor drive systems using wide bandgap devices," 2014 IEEE Workshop on Wide Bandgap Power Devices and Applications, Knoxville, TN, 2014, pp. 164-168. d
- [8] L. Ru and L. Ying-zi, "A kind of new simulation of electric field distribution in a PWM inverter-fed motor stator winding subjected to steep-fronted surge voltages," 2011 6th IEEE Conference on Industrial Electronics and Applications, Beijing, 2011, pp. 2787-2790.
- [9] Sangcheol Lee and Kwanghee Nam, "An overvoltage suppression scheme for AC motor drives using a half DC-link voltage level at each PWM transition," in IEEE Transactions on Industrial Electronics, vol. 49, no. 3, pp. 549-557, June 2002. doi: 10.1109/TIE.2002.1005379.
- [10] J. He, H. Chen, R. Katebi, N. Weise and N. A. O. Demerdash, "Mitigation of uneven surge voltage stress on stator windings of induction motors fed by SiC-MOSFET-based adjustable speed drives," 2017 IEEE International Electric Machines and Drives Conference (IEMDC), Miami, FL, 2017, pp. 1-7.
- [11] W. Yin, L. Durantay, L. Zhang, S. U. Haq and F. Vannay, "End Winding Protections Improvements Helping To Downsize dV/dt Filter For Medium Voltage Machine Fed By NPP Multi-Levels VSI Drive," 2018 IEEE 2nd International Conference on Dielectrics (ICD), Budapest, 2018, pp. 1-4. doi: 10.1109/ICD.2018.8514673.
- [12] M. M. Swamy, J. Kang and K. Shirabe, "Power Loss, System Efficiency, and Leakage Current Comparison Between Si IGBT VFD and SiC FET VFD With Various Filtering Options," in IEEE Transactions on Industry Applications, vol. 51, no. 5, pp. 3858-3866, Sept.-Oct. 2015. doi: 10.1109/TIA.2015.2420616.
- [13] G. Skibinski, "Design methodology of a cable terminator to reduce reflected voltage on AC motors," IAS '96. Conference Record of the 1996 IEEE Industry Applications Conference Thirty-First IAS Annual Meeting, San Diego, CA, USA, 1996, pp. 153-161 vol.1.
- [14] P. Mart-ro, W. Sae-Kok and S. Khomfoi, "Analysis of dv/dt filter installation for PWM AC drive applications," 2011 IEEE Ninth International Conference on Power Electronics and Drive Systems, Singapore, 2011, pp. 177-184. doi: 10.1109/PEDS.2011.6147243.
- [15] H. Kim, B. Kim and S. Bhattacharya, "An Analytical Design Strategy and Implementation of a dv/dt Filter for WBG Devices Based High Speed Machine Drives," IECON 2018 - 44th Annual Conference of the IEEE Industrial Electronics Society, Washington, DC, 2018, pp. 385-390. doi: 10.1109/IECON.2018.8591737.
- [16] J. He et al., "Multi-Domain Design Optimization of dv/dt Filter for SiC-Based Three-Phase Inverters in High-Frequency Motor-Drive Applications," 2018 IEEE Energy Conversion Congress and Exposition (ECCE), Portland, OR, 2018, pp. 5215-5222.
- [17] C. Vadstrup, X. Wang and F. Blaabjerg, "LC filter design for wide band gap device based adjustable speed drives," 2014 International Power Electronics and Application Conference and Exposition, Shanghai, 2014, pp. 1291-1296. doi: 10.1109/PEAC.2014.7038049.
- [18] M. M. Swamy and M. A. Baumgardner, "New Normal Mode dv/dt Filter With a Built-In Resistor Failure Detection Circuit," in IEEE Transactions on Industry Applications, vol. 53, no. 3, pp. 2149-2158, May-June 2017. doi: 10.1109/TIA.2017.2672519.
- [19] T. G. Habetler, R. Naik and T. A. Nondahl, "Design and implementation of an inverter output LC filter used for dv/dt reduction," in IEEE Transactions on Power Electronics, vol. 17, no. 3, pp. 327-331, May 2002. doi: 10.1109/TPEL.2002.1004240.
- [20] R. Mini, S. R. Resna and M. N. Dinesh, "LC clamp filter for voltage reflection due to long cable in induction motor drives," 2014 Annual International Conference on Emerging Research Areas: Magnetics, Machines and Drives (AICERA/iCMMD), Kottayam, 2014, pp. 1-6.
- [21] Y. Liu, L. Wang, H. Gao, H. Zhang and D. Xu, "Overvoltage mitigation of submersible motors with long cables of different lengths," 2014 17th International Conference on Electrical Machines and Systems (ICEMS), Hangzhou, 2014, pp. 638-644.
- [22] N. B. Elsayed, M. E. Ibrahim and M. A. Izzularab, "Mitigation of Overvoltages at Induction Motor Terminals Fed from an Inverter Through Long Cable," 2018 Twentieth International Middle East Power Systems Conference (MEPCON), Cairo, Egypt, 2018, pp. 595-602.
- [23] K. K. Yuen and H. S. Chung, "A Low-Loss "RL-Plus-C" Filter for Overvoltage Suppression in Inverter-Fed Drive System With Long Motor Cable," in IEEE Transactions on Power Electronics, vol. 30, no. 4, pp. 2167-2181, April 2015. doi: 10.1109/TPEL.2014.2325824.
- [24] X. Chen, D. Xu, F. Liu and J. Zhang, "A Novel Inverter-Output Passive Filter for Reducing Both Differential- and Common-Mode $\delta v/dt$ at the Motor Terminals in PWM Drive Systems," in IEEE Transactions on Industrial Electronics, vol. 54, no. 1, pp. 419-426, Feb. 2007.
- [25] G. Qiang and X. Dianguo, "A New Approach to Mitigate CM and DM Voltage dv/dt Value in PWM Inverter Drive Motor Systems," APEC 07 - Twenty-Second Annual IEEE Applied Power Electronics Conference and Exposition, Anaheim, CA, USA, 2007, pp. 1212-1216.
- [26] H. Akagi and T. Doumoto, "An approach to eliminating high-frequency shaft voltage and ground leakage current from an inverter-driven motor," in IEEE Transactions on Industry Applications, vol. 40, no. 4, pp. 1162-1169, July-Aug. 2004. doi: 10.1109/TIA.2004.830748.
- [27] Velander et al., "An Ultralow Loss Inductorless dv/dt Filter Concept for Medium-Power Voltage Source Motor Drive Converters With SiC Devices," in IEEE Transactions on Power Electronics, vol. 33, no. 7, pp. 6072-6081, July 2018. doi: 10.1109/TPEL.2017.2739839.
- [28] Schroedermeier and D. C. Ludois, "Integrated inductors, capacitors, and damping in bus bars for dv/dt filter applications," 2018 IEEE Applied Power Electronics Conference and Exposition (APEC), San Antonio, TX, 2018, pp. 2650-2657. doi: 10.1109/APEC.2018.834139.
- [29] S. Yue, Q. Yang, Y. Li, C. Zhang and G. Xu, "Core loss calculation of the soft ferrite cores in high frequency transformer under non-sinusoidal excitations," 2017 20th International Conference on Electrical Machines and Systems (ICEMS), Sydney, NSW, 2017, pp. 1-5. doi: 10.1109/ICEMS.2017.8056411.
- [30] R. He, Y. Zhang, D. Zhang and D. Xie, "An Improvement of Core Losses Estimation Model in Power Electronic Transformer," 2018 IEEE Student Conference on Electric Machines and Systems, HuZhou, China, 2018, pp. 1-5. doi: 10.1109/SCEMS.2018.8624711.
- [31] R. Burkart and J. W. Kolar, "Component cost models for multi-objective optimizations of switched-mode power converters," 2013 IEEE Energy Conversion Congress and Exposition, Denver, CO, 2013, pp. 2139-2146. doi: 10.1109/ECCE.2013.6646971