

This is the peer reviewed version of the following article:

Rutherford Backscattering Spectrometry: a technique worth introducing into pedagogy / Corni, Federico; Ottaviani, Giampiero; Michelini, M; Michelutti, G. L.; Santi, L; Stefanel, A.. - STAMPA. - (1996), pp. 266-272. (Teaching the Science of Condensed Matter and New Materials Udine 24-30 Agosto 1995).

FORUM

Terms of use:

The terms and conditions for the reuse of this version of the manuscript are specified in the publishing policy. For all terms of use and more information see the publisher's website.

05/05/2026 18:22

(Article begins on next page)

2.6 Teaching Advanced Topics in Condensed Matter

RUTHERFORD BACKSCATTERING SPECTROMETRY: A TECHNIQUE WORTH INTRODUCING INTO PEDAGOGY

F. Corni, G. Ottaviani, *Department of Physics, University of Modena (Italy)*

M. Michelini, G.L. Michelutti, L. Santi, A. Stefanel, *Research Unit in Physics Education, University of Udine (Italy)*

1. Techniques of Analysis in the Physics of Materials.

Up to today, a great deal of the research in materials science was devoted to the analysis of equilibrium and transport properties, like electrical and optical, and phase transitions. Today property analysis (characterization) is a standard section of most part of research in material and new materials science. Research in this field covers a wide area, including the investigation of some basic aspects in Physics, the investigation of applicatory aspects and the links with other modern technological applications. The techniques of analysis are based on measurements of macroscopical properties and on their changes in relationship with the modification of microscopical properties or with the answers given by probes able to interact with the microscopic world. Often they are developed having as basic principle some crucial experiment in history of physics; Rutherford Backscattering Spectrometry (RBS), for example, is inspired by Rutherford's experiment. Examples of the more common measurements carried out are resistivity and its temperature behaviour, Hall coefficient, reflectivity and time resolved reflectivity, photoconductivity, x-ray diffraction, RBS. The last one is proposed for educational activity in this work. The traditional topics can be treated deeply introducing examples of specific analysis in real contexts. They become also motivating if these examples are relative to significant useful applications in different fields. Explicit connections between basic ideas and applications produce knowledge because of the different contexts of phenomenon analysis. In addition the understanding of some modern research procedures and techniques is useful to update the curriculum. Updating the curriculum cannot be a simple addition of contents: new topics must be integrated in the basic ideas of the discipline. The characterization can also play the role of bridge from classical description of macroscopic behaviour to microscopic properties with their quantistic description. This realizes the above mentioned wanted integration. In this work we describe a specific educational proposal aimed to exemplify a way to introduce a bridge between classical and quantum physics with attention to a modern application of classical ideas and to new motivating information on new material science. We intend to discuss how it is possible to create a direct link between the basic knowledge of secondary school students and the contents of material physics through the study of RBS. To make the students aware of the nature of the results of this kind of analysis, we suggest a guided discussion of spectra carefully chosen in order to highlight the specific information obtained from such a technique.

2. RBS, Rutherford Experiment and physics education

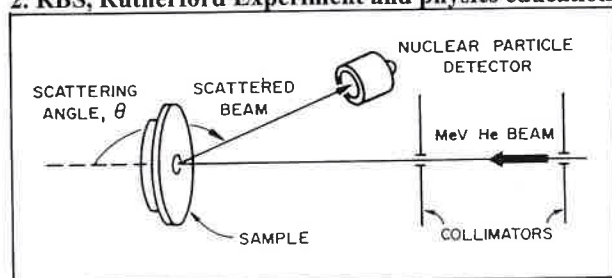

Figure 1. RBS experimental scheme¹.

RBS is performed by sending a few MeV ion beam, e.g. alpha particles, toward a sheet of material and analyzing the energy spectrum of the backscattered particles, placing in a chosen direction ($\theta \approx 180^\circ$) a solid state detector (figure 1). Therefore it is a nuclear collision based experiment used in material science for in-depth compositional analysis of laterally

(e.g., layer the scattering target nuclei layers of the application studied only of scattering therefore us be used to accessible t their first tv and introdu opportunity factor, cross students abl gradual gain to deal with software fo program by

3. Collision

The key poi to students. are few fun particles is a particles of high enough the electron and the p excitation. F not as easy seem and it gradually. F the collision balls. In this the relation states and involved ob effectiveness laws of mo energy. It is beginning it the force scattering a rigid sphere This approa high energy v_{10} and v_{20} r

(e.g., layer by layer) uniform samples. Knowing the mass and the energy of the impinging ions and the scattering angle θ it is suitable to obtain informations on the concentration and the masses of the target nuclei as well as their distance from the surface, with an error of 5 nm on thickness for sample layers of the order of 500 nm and a few percent on composition. This technique consists in an application of the Rutherford experiment. During courses in basic physics, this experiment is often studied only in a qualitative way for its historical importance. It is, however, a fundamental example of scattering as well as a reference topic for many research techniques in nuclear physics: it is therefore useful to explore it in a deeper analysis and, if possible, with a physical discussion. RBS can be used to motivate a semiquantitative approach, using classical physics with a level of formalism accessible to final-year students of high school (Liceo Scientifico) as well as university students in their first two years. It can thus be used as an opportunity for revising basic concepts in mechanics and introducing a quantitative discussion of the coulombian collision. In addition RBS offers the opportunity to introduce concepts which are widely used in research in physics such as kinematic factor, cross section and statistical stopping power. The proposed teaching strategy aims to make the students able to interpret the more significant characteristics of RBS spectra, having as guideline the gradual gain in interpretation ability. It is not necessary to go into the specific field of this technique to deal with it in a quantitative and research-like way. This can also be supported by the use of a software for computerized spectra analysis and process simulation. For example, a widely used program by physicists is RUMP by Doolittle^{2,3}.

3. Collision Physics and RBS

The key point of this educational approach to RBS is the use of basic and simple concepts well-known to students. This is to give experience that even on the background of complicated processes there are few fundamental ideas and laws. The coulombian elastic scattering between two point-like particles is an effective tool to interpret, both qualitatively as well as quantitatively, the hitting by α -particles of the nuclei of the atoms of a thin film of material. In fact, the energy of the α -particle is high enough to make the α -particle approach the target nucleus so much that the scattering effect of the electron is negligible, but little enough to allow us to neglect the finite size of interactive bodies and the phenomenon of nucleus excitation. However, such a model is not as easy and intuitive as it may seem and it needs to be introduced gradually. First we should consider the collision processes of billiard balls. In this way it is possible to find the relationship between the initial states and the final states of the involved objects and to highlight the effectiveness of the conservation laws of momentum and mechanical energy. It is to be noticed that at the beginning it is not necessary to know the force responsible for the scattering and simply assume the rigid sphere collision model.

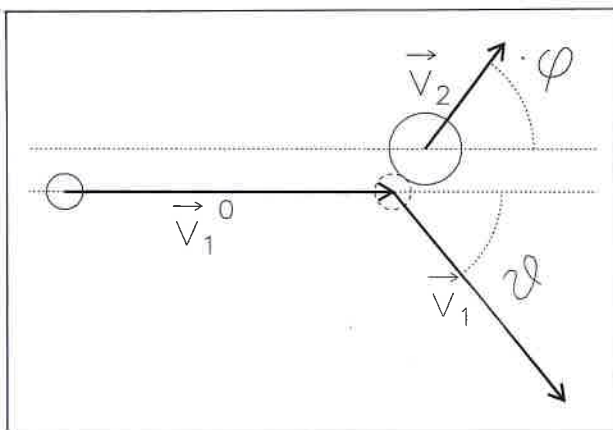

Figure 2. Rigid sphere collision.

This approach is general and valid for all kinds of elastic collisions, from billiard balls to particles in high energy accelerators. For two rigid spheres with masses M_1 and M_2 , moving at initial speeds of v_{10} and v_{20} respectively, we can write the following equations which define the conservation laws.

$$E_{10} + E_{20} = E_1 + E_2$$

$$M_1 v_{10} + M_2 v_{20} = M_1 v_1 + M_2 v_2$$

where all quantities in the first part of the equation (with the $_0$) refer to the initial situation and

$$E_i = (1/2)M_i v_i^2 \quad (i = 1, 2).$$

Consider figure 2: M_1 is in motion and M_2 is initially still. So expressions related to M_2 do not appear in the first part of the equations and the collision takes place on a single level. The two equations can thus be written as follows:

$$E_{10} = E_1 + E_2$$

$$M_1 v_{10} = M_1 v_1 \cos(\theta) + M_2 v_2 \cos(\theta)$$

$$0 = M_1 v_1 \sin(\theta) - M_2 v_2 \sin(\theta)$$

From the above equations the following are derived:

$$E_1 = E_{10} \left[\frac{M_1 + \sqrt{M_2^2 - M_1^2 \sin^2(\theta)}}{M_1 + M_2} \right]^2 = K E_{10} \quad (1)$$

$$E_2 = E_{10} \left(\frac{4M_1 M_2}{(M_1 + M_2)^2} \cos^2(\varphi) \right) = K' E_{10} \quad (1')$$

The final energies of the spheres are proportional to the initial energy E_0 . The proportionality coefficients K and K' are called kinematic factors and indicate the fraction of energy lost by the first sphere recoiling the target sphere and the fraction of initial total energy imparted to the second sphere respectively. The results obtained are valid for particles interacting via r -dependent repulsive forces in the case of RBS (figure 3). In a RBS spectrum of a thin layer of atoms it is possible to recognize the elements contained evaluating their masses from the K factors obtained by the ratio between

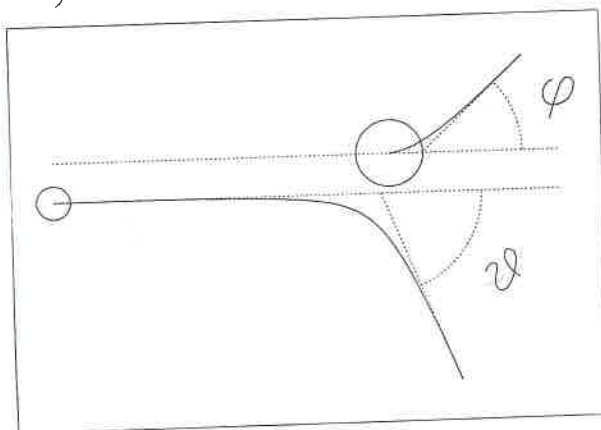

Figure 3. Particle interaction via r -dependent potential (Coulomb)

the energies of the peaks in the spectrum and the beam initial energy on thin films. With thin films technique it is possible also to have information about the atomic fractions of the elements and, in the case of buried layers, about their depth-profiles. To study the equations that govern the scattering efficiency (related to sample composition) and the energy loss due to the penetration in matter (related to sample thickness) it is necessary to introduce the Coulombian force. In order to keep the calculation simple and easily understandable it is better to choose a suitable framework in which the target nucleus

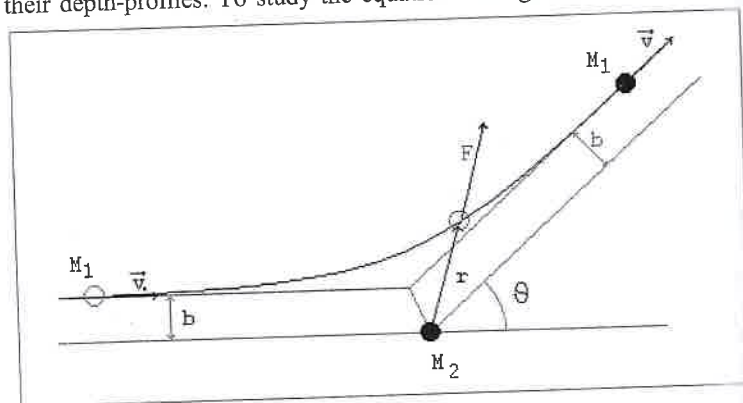

Figure 4. Coulomb scattering in the case $M_2 \gg M_1$

is supposed at rest in the origin (figure 4). This approximation is allowed in RBS because this technique employs light ions (H^+ and He^{++}) to analyze medium and heavy masses and the recoil velocity of the target nucleus M_2 compared with that of the incident particle M_1 , after the collision, is very small. To show this one can compare v_2 and v_1 by means of eq. (1) and (1') in the simple case of $\theta \approx 180^\circ$. For example, for Cu, Ag and Au target atoms, the ratio $v_2/v_1 = 2M_1/(M_2 - M_1)$ is 0.14, 0.08 and 0.04 respectively. As the force of interaction is central, the angular momentum of the incident particle is approximatively preserved. The problem can be solved with the equations that define the conservation of energy and angular momentum. In the case of a coulombian collision we can apply the second law of dynamics and evaluate the total variation of the impulse of the particle scattered, using the conservation of the angular momentum in order to determine the relationship between impact parameters (the distance between the initial direction of incidence and the diffusing nucleus) and the scattering angle². The only mathematical difficulty is represented by the evaluation of the integral of the cosine, although this can also be derived from a finite difference calculation. An alternative method is to use the fact that the Coulomb force determines with $E_{10} > 0$ a hyperbolic trajectory with the diffusing nucleus at the focus. Analytic geometry supplies the distance between the asymptote and the focus. In all cases we get the following equation:

$$b = \left(Z' Ze^2 / 2E_{10} \right)^2 \cot(\theta / 2) \tag{2}$$

where Z', Z are the atomic numbers of the incident particle and of the target nucleus.

In a RBS measurement, a beam of α -particles, of an homogenous section, collides with the target. It is therefore natural to ask which will be the number N_{det} of particles scattered in direction of the detector in relation to the number N_i of incident particles. In other words, what is the fraction of the particles scattered in a certain direction within the solid angle Ω of acceptance of the counter.

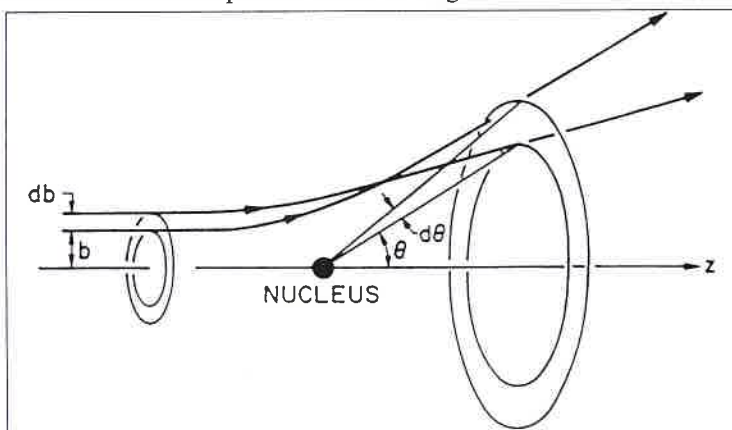

Figure 5. Relationship between impact parameter and scattering angle of the incident particle¹.

Let us consider the case of a single nucleus (figure 5). The α -particles that cross a circular crown of radius b and thickness db are deflected at angles between θ and $\theta + d\theta$. Of these only the fraction

$$\frac{\Omega}{2\pi \sin(\theta) d\theta}$$

reaches the detector. If we indicate the sample thickness with t , its atomic density with n and the ion beam section with S , the ratio $2\pi b db/S$ gives the fraction of α -particles which undergo deflection at angles between θ and $\theta + d\theta$ for one nucleus, so the total number of particles entering the detector is:

$$N_{det} = N_i \cdot \text{number of target nuclei} \cdot \frac{2\pi b db}{S} \cdot \frac{\Omega}{2\pi \sin\theta d\theta} = N_i n t \frac{b}{\sin(\theta)} \frac{\Omega}{d\theta}$$

Using eq.(2) we derive:

$$N_{det} = N_i n t \left[\left(\frac{Z' Ze^2}{4E_{10}} \right) \frac{1}{\sin^4(\theta / 2)} \right] \Omega \tag{3}$$

which is the well-known Rutherford equation of the cross section. In the specific case of the RBS technique, backscattering implies that $\theta \approx 180^\circ$, $\sin(\theta) \approx 0$, $\sin(\theta/2) \approx 1$ and $\cos(\theta) \approx -1$. From equations (1) and (3) the following are derived:

$$E_1 \approx E_{10} \left[\frac{M_2 - M_1}{M_2 + M_1} \right]^2 \tag{4}$$

$$N_{\text{det}} = N_t n t \left(\frac{Z^1 Z e^2}{4E_{10}} \right)^2 \tag{5}$$

4. Reading and Interpreting the RBS Spectrum from a Monatomic Layer

A RBS spectrum is shown in figure 6. On the axis of the ordinates is the number of counts according to the channel number, that corresponds to the energy of the α -particles detected by the counter through a previously calculated linear calibration. The spectrum is obtained by hitting a monoatomic layer compounded of about the same quantity of copper, silver and gold atoms.

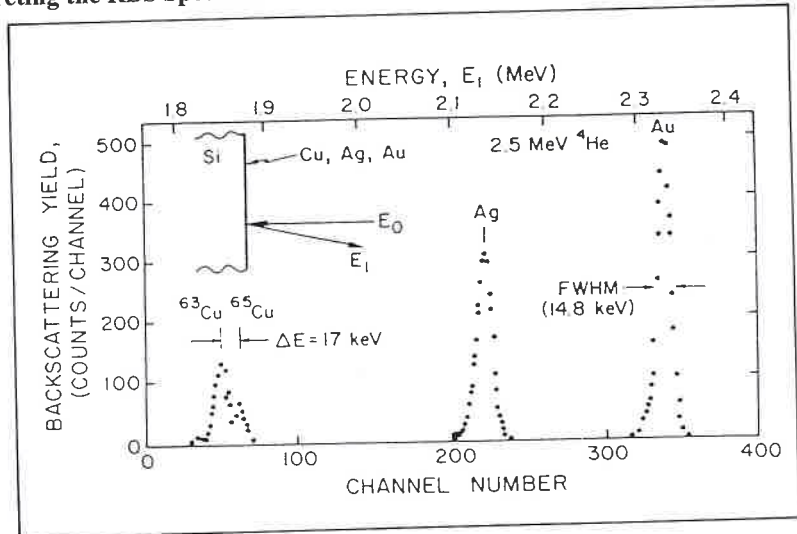

Figure 6. RBS spectrum. Monoatomic layer target ($\approx 10 \text{ nm}$)⁵.

The spectrum peaks are of different heights and all but one have a symmetrical shape. Eq.(4) shows that the energy of the diffused α -particles increases with the mass of the scattering nucleus, whilst from eq.(5) we derive that the cross section is proportional to the square of the atomic number of the scattering nucleus itself. It therefore increases with its mass. This allows us to understand why copper, silver and gold, in this order of increasing mass, create peaks of increasing energy and increasing intensity. The copper peak is split because of the presence of two isotopes (Cu^{63} and Cu^{65}). Silver does have two isotopes too (Ag^{107} and Ag^{109}) but these are not evident because the relative difference between the masses $\Delta M_2/M_2$ is smaller. The difference between the masses ΔM_2 next to each other creates a difference in the energy of the scattered particles as shown in the following equation obtained by differentiating eq.(4) and assuming $M_2 - M_1 \approx M_2 + M_1 \approx M_2$:

$$\Delta E_1 = E_{10} \frac{M_1}{M_2^2} \Delta M_2$$

From this equation, the higher the mass M_2 , the lower the energy difference. To improve the resolution for heavy target atoms heavier incident ions, such as N^+ , should be used. Alternatively the beam energy must be increased.

5. Depth Profiling and Stopping Power

As we have already mentioned, the RBS technique is used in depth-profiling of samples. The α -particles of a beam, hitting a relatively thick sample, can be scattered from the surface atoms

as well as from atoms below the surface. As α -particles penetrate into the sample they lose energy due to a very large number of elastic collisions with the electrons of the target. So the energy at which the collision takes place reduces according to the depth at which it happens. Since the exact number of such electronic collisions and their relative energy transfer is not exactly evaluable a statistical quantity is defined that represents the energy loss per unit of thickness. It is expressed by the following equation:

$$\varepsilon = \frac{1}{n} \frac{\Delta E}{t}$$

ε is called the stopping power and is a function of the energy of the α -particle. Dimensionally it is an energy times a surface. It indicates how much each atom of the sample contributes on average to the loss of energy of an α -particle as it crosses the unit of thickness. An α -particle which enters a sample of thickness t and is not backscattered by the upper layers, will lose an energy equal to $n t \varepsilon (E_{10})$. If it undergoes a backscattering by the layer at depth t in the direction of the counter, it will cross a thickness of material equal to $t/\cos(\theta)$ (figure 7), with a further energy loss of:

$$n [t / (\cos\theta)] \varepsilon (KE_1)$$

where K is the kinematic factor of the diffusing nucleus. Considering the difference ΔE between the energy of the α -particles scattered by the first monatomic layer and that of the particles scattered by the last layer of the sample at a depth t , the following equation is derived ($\cos\theta \approx 1$)

$$\Delta E = nt [K \varepsilon (E_{10}) + \varepsilon (KE_1)] \quad (6)$$

The expression within square parentheses depends only on the material of the system analyzed. Eq.(6) allows to measure the thickness t of a layer by measuring the width of the corresponding energy

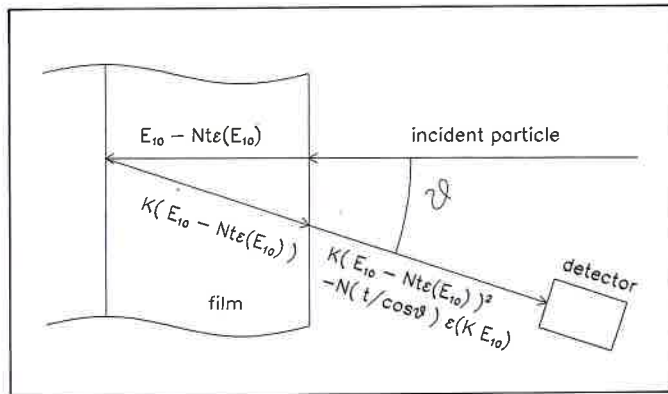

Figure 7. The incident particles with energy E_{10} penetrate into a sample of thickness t : backscattered towards the detector, their energy is reduced by a factor K and they cross again a thickness t of material.

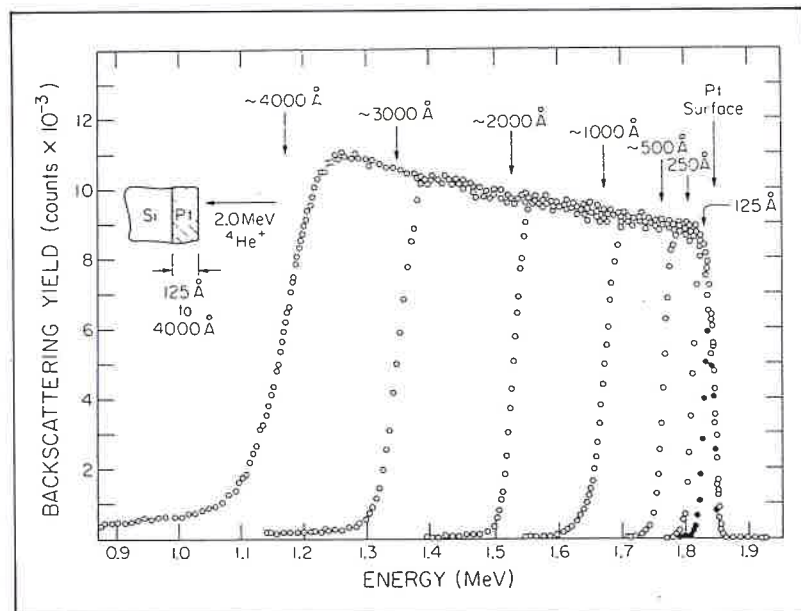

Figure 8. RBS Spectrum. Many layer target ($12.5 \leq t \leq 400 \text{ nm}$)⁵.

band ΔE in the RBS spectrum. The layered spectra of a platinum sample with thicknesses from 12.5 nm up to 400 nm are shown in figure 8. As the energy ΔE lost by the particles crossing a layer is proportional to its thickness, as shown in eq.(6), it is understandable why the width of the spectra increases with the increase of thickness. All spectra have a high energy shoulder in common which is produced by scattering from the Pt surface atoms of the films. It is important to notice that the thickness is not determined unambiguously by the measure of ΔE . RBS, as all nuclear techniques, supplies information about the number of atoms per unit of surface, i.e. on nt , and not on n and t separately. It is therefore necessary to have information on one of the two quantities in order to evaluate the other one by means of eq.(6). The same spectra in figure 8 could have been obtained with less dense but thicker samples of Pt components.

6. Concluding remarks

The Rutherford Backscattering Spectrometry (RBS), which until a few years ago was an important area of research in the physics of solids, is today almost a routine technique of analysis in the characterisation of samples. It consists in the use of Rutherford's experiment which permits the analysis of the type and the depth-distribution of the elements forming the surface of a sample. The basic knowledges required for its understanding are all contained in secondary school physics curricula. Therefore we organized an educational proposal having as aim a passage to the understanding of the experimental bases of the physics of solids and a motivational application of the topics which are propaedeutic for it and fundamental in its interpretation, as conservation principles of energy and momentum. Two levels of suggestions are individuated. One level deals with the preparation of a collection of educational materials on techniques of analysis and the characterisation of properties. The other level contains the more specific suggestion based on the analysis of experimental data, which allows a gradual approach to RBS. The problem solving strategy is adopted to realize concrete learning in the topic and to make students able to interpret the results of measurements .

References

1. L.C. Feldman, J.W. Mayer, *Fundamentals of Surface and Thin Film Analysis*, Amsterdam, North-Holland (1986)
2. L.R. Doolittle, Nucl. Instr. Meth. B9 (1985) 344
3. L.R. Doolittle, Nucl. Instr. Meth. B15 (1986) 277
4. J.B. Marion, "Particle and Rigid Body Dynamics", in *PSSC* vol.4
5. W.K. Chu, J.W. Mayer, M.A. Nicolet, *Back Scattering Spectrometry*, New York, Academic Press (1978)

OPTICAL SOLITONS AS RELATIVISTIC MIRRORS

M.J. Martins, *Center for Electrodynamics Technical University, Lisboa (Portugal)*

1. Introduction

Optical solitons represent the envelope of a light wave that establishes itself as a stable solution in a non-linear dispersive medium. The nonlinearity is due to the Kerr effect which causes the medium properties to be dependent on the square power of the electric field of the light wave. Due to the Kerr effect there is a self induced pulse broadening which is compensated by the group dispersion, in the anomalous dispersion zone. The propagation of a soliton through a medium creates a nonstationary disturbance of the medium refractive index which propagates with velocity $\beta=v/c$, close to unity. The interaction of a wave of small intensity with the soliton originates a reflection which causes a double Doppler shift of the wave frequency, that can attain very high values.

2. Optical solitons

Dispersion causes the signal velocity to be dependent on frequency (or wavelength). Therefore, signal propagation in dispersive media requires the definition of the input signal.

We shall consider for the sake of simplicity, a gaussian pulse, with central frequency ω_0 , that