

This is the peer reviewed version of the following article:

Mutations in TOPORS Cause Autosomal Dominant Retinitis Pigmentosa with Perivascular Retinal Pigment Epithelium Atrophy / Chakarova, C. F.; Papaioannou, M. G.; Khanna, H; Lopez, I; Waseem, N; Shah, A; Theis, T; Friedman, J; Maubaret, C; Bujakowska, K; Veraitch, B; Abd El Aziz, M. M.; Prescott, D. Q.; Parapuram, S; Bickmore, W. A.; Munro, P. M. G.; Gal, A; Hamel, C; Marigo, Valeria; Ponting, C. P.; Wissinger, B; Zrenner, E; Matter, K; Swaroop, A; Koenekoop, R. K.; Bhattacharya, S. S.. - In: AMERICAN JOURNAL OF HUMAN GENETICS. - ISSN 0002-9297. - STAMPA. - 81:5(2007), pp. 1098-1103. [10.1086/521953]

University of Chicago Press:PO Box 37005, Journals Division:Chicago, IL 60637:(877)705-1878, (877)705-  
*Terms of use:*

The terms and conditions for the reuse of this version of the manuscript are specified in the publishing policy. For all terms of use and more information see the publisher's website.

30/04/2026 20:21

(Article begins on next page)

30/04/2026 20:21

## **Mutations in *TOPORS* Cause Autosomal Dominant Retinitis Pigmentosa with Perivascular RPE Atrophy**

Christina F. Chakarova\*, Myrto G. Papaioannou\*, Hemant Khanna, Irma Lopez, Naushin Waseem, Amna Shah, Torsten Theis, James Friedman, Cecilia Maubaret, Kinga Bujakowska, Brotati Veraitch, Mai M. Abd El-Aziz, De Quincy Prescott, Sunil Parapuram, Wendy A. Bickmore, Peter M.G. Munro, Andreas Gal, Christian Hamel, Valeria Marigo, Chris P. Ponting, Bernd Wissinger, Eberhart Zrenner, Karl Matter, Anand Swaroop, Robert K. Koenekoop and Shomi S. Bhattacharya

From Institute of Ophthalmology, UCL, London, UK (C.F.C.; M.G.P.; N.W.; A.S.; T.T.; C.M.; K.B.; B.V.; M.M.A.E.; D.Q.P.; P.M.G.M.; K.M.; S.S.B.); Departments of Ophthalmology & Visual Sciences, University of Michigan, Ann Arbor, USA (H.K.; J.F.; S.P.; A.S.); The McGill Ocular Genetics Laboratory, McGill University Health Centre, Montreal, Quebec, Canada (I.L.; R.K.K.); The MRC Human Genetics Unit, Edinburgh, UK (W.A.B.); Institute of Human Genetics, Hamburg, Germany (A.G.); INSERM, Montpellier, France (C.H.); Department of Biomedical Sciences, University of Modena and Reggio Emilia, Modena, Italy (V.M.); The MRC Functional Genetics Unit, University of Oxford, Department of Human Anatomy and Genetics, Oxford, UK (C.P.P.); and Department of Pathophysiology of Vision and Neuro-Ophthalmology, University Eye Hospital, Tübingen, Germany (B.W.; E.Z.)

\*The first two authors contributed equally to the article

Address for correspondence and reprints: Shomi S. Bhattacharya, Institute of Ophthalmology, UCL, London, UK. E-mail: [smbcssb@ucl.ac.uk](mailto:smbcssb@ucl.ac.uk)

Running title: *TOPORS* mutations in ad RP

**Abstract**

We report mutations in the gene for TOPOisomerase I - binding - RS protein (*TOPORS*, MIM 609507) in patients with autosomal dominant retinitis pigmentosa (adRP) linked to chromosome 9p21.1 (*RP31*). A positional cloning approach, together with bioinformatics, identified *TOPORS* (comprising three exons and encoding a protein of 1045 amino acids) as the gene responsible for adRP. Mutations that include an insertion and a deletion have been identified in one French Canadian and one German adRP family, respectively. Interestingly, a distinct phenotype is noted at earlier stages of the disease with an unusual perivascular cuff of RPE atrophy, which was found surrounding the superior and inferior arcades in the retina. *TOPORS* is a RING domain-containing E3 ubiquitin ligase and localizes in the nucleus in speckled loci that are associated with PML bodies. The ubiquitous nature of *TOPORS* expression and a lack of mutant protein in patients are highly suggestive of haplo-insufficiency rather than a dominant negative effect as the molecular mechanism of the disease and makes rescue of the clinical phenotype amenable to somatic gene therapy.

Retinitis pigmentosa (RP) is a clinically and genetically heterogeneous disorder with incidence of 1 in 3500 or a total of 1.8 million people worldwide. Affected individuals suffer from a progressive degeneration of the photoreceptors, eventually resulting in severe visual impairment. The mode of inheritance of RP can be autosomal dominant (adRP), recessive (arRP), X-linked or digenic.<sup>1</sup> To date, at least sixteen causative genes have been identified for adRP (RetNet, <http://www.sph.uth.tmc.edu/Retnet/> and MIM 114760, 602225, 607643, 602275, 146690, 604485, 162080, 607301, 607300, 606419, 179605, 180380, 180721, 603937, 607331, 607292), and the products of these genes are associated with photoreceptor structure, cellular function including the phototransduction cascade, or gene expression, including transcription and mRNA-splicing.<sup>2</sup>

Recently, we reported a new locus for adRP (*RP31*, MIM 609923) in a three-generation family based in the province of Quebec, Canada.<sup>3</sup> After exclusion of all known loci for adRP, a genome-wide search established positive linkage with a marker from the short arm of chromosome 9 (LOD score of 6.3 at recombination fraction  $\theta = 0$ ). The linked region is flanked by markers D9S157 and AFMe153td9 on 9p22-p21.1, corresponding to a physical distance of 15 Mb.<sup>3</sup>

Since the previous report, seventeen members with RP from this family, ranging in ages from 8-64 years, were clinically re-examined in Montreal Children's Hospital Research Institute (Montreal, Canada). Onset of symptoms ranged from 10-50 years and differed between the generations, while three affected patients were found to be asymptomatic. Visual acuities (range 20/20 to finger counting) were maintained in most patients as 16/17 had better than 20/40 and 11/17 had 20/20 acuities at the last visit. Visual field sizes ranged from 10°-80° and ERG abnormalities were highly variable as

well, with early rod dysfunction followed by cone defects. The earliest sign of disease (found in four children) was an unusual perivascular cuff of RPE atrophy, which was found surrounding the superior and inferior arcades (fig. 1). This progressed to a diffuse pigmentary retinopathy with choroidal sclerosis. Three patients with the disease haplotype were asymptomatic and had completely normal retinal appearance, nonetheless their ERG abnormalities were similar to the symptomatic patients. This phenotype differs significantly from the clinical diagnosis associated with the other 16 published adRP gene defects. A detailed description of the phenotype will be published elsewhere.

Linkage analysis spanning the disease locus on chromosome 9p21 refined the genetic interval to 14 Mb between markers IVS4-46G (*NP\_060395.3*) and AFMa153td9; this critical region contains 48 known and 5 novel (hypothetical) genes. The list of genes (from telomere to centromere of chromosome 9p) that have been systematically screened, and in the following order, includes *NP\_060395.3*, *RPS6*, *ASAH3L*, *SLC24A2*, *MIIT3*, *KIAA1797*, *NP\_001010915.1*, *IFNB1*, *IFNW1*, *IFNA21*, *IFNA4*, *IFNA14*, *IFNA10*, *IFNA17*, *IFNA5*, *KLHL9*, *IFNA6*, *NP\_008831.2*, *IFNA2*, *IFNA8*, *IFNA1*, *Q8WTY6*, *NP\_795372.1*, *MTAP*, *NSGX*, *NP\_478102.1*, *CDKN2A*, *CDKN2B*, *DMRTA1*, *ELAVL2*, *TUSC1*, *NP\_079104.2*, *PLAA*, *CCDC2*, *LRRC19*, *TEK*, *MP\_065692.1*, *MOBKL2B*, *IFNK*, *NP\_659442.2*, *NP\_689783.1*, *Q5T776*, *ACO1*, *DDX58*, *TOPORS*, *NDUFB6*, *TAF1L* and *NP\_997723.1* (Ensembl, <http://www.ensembl.org/index.html>). All exons and their respective acceptor and donor splice sites were directly analyzed from the PCR products using ABI BigDye™ terminator cycle sequencing kit v3.1 (Applied Biosystems, Cheshire, UK) on an ABI-3100 Genetic Analyzer. Most of the genes

encode proteins with well-documented functions. From this list of 53 genes, two were prioritized for immediate screening due to their specific expression and known retinal function: retinal cone Na-Ca+K-exchanger (*SLC24A2*, MIM 609838), which is abundantly expressed in cone photoreceptors and retinal ganglion cells;<sup>4</sup> and embryonic lethal abnormal visual RNA-binding protein involved in growth, differentiation, and posttranscriptional gene expression (*ELAVL2*, MIM 601673), which plays an important role in the RNA-processing.<sup>5</sup> No disease-causing mutations were identified in these two genes. We then continued with our systematic mutation screening of all expressed genes from the candidate region. Several of the genes contained sequence changes that were also identified in healthy unrelated controls, confirming that the variant is benign.

Sequence analysis of one of the genes, *TOPORS* (NM\_005802, MIM 609507), a 13 kb gene with 3 exons,<sup>6</sup> revealed a heterozygous 1 bp insertion (c.2474\_2475insA) in exon 3; this frameshift mutation segregates with the affected status and is predicted to result in a premature stop codon (p.Tyr825fs) (fig. 2A,B). We also identified a second *TOPORS* mutation, a 2 bp deletion (c.2552\_2553delGA) in exon 3 leading to p.Arg851fs, in a small German family (fig. 2C,D). We did not detect these changes in a control panel of 200 individuals of Caucasian origin. Primer sequences for mutation analysis of all 3 exons of *TOPORS* are listed in table 1. The presence of two distinct heterozygous frame-shift mutations in two independent families strongly argues that mutations in *TOPORS* are responsible for *RP31*. Sequencing of the coding regions of all other genes in the *RP31* critical region revealed only non-pathogenic sequence variants. The second *TOPORS* mutation was identified as a result of our screening of a

panel of 65 unrelated German adRP patients attending the Retina Clinic at University Eye Hospital, Tübingen. Based on these preliminary findings it is likely that *TOPORS* mutations are a rare cause of retinal degeneration.

The *TOPORS* gene encodes a major transcript of 3.1 kb, which produces a multi-domain protein of 1045 amino acids with an N-terminal RING-type zinc finger domain (amino acids 103-141), five stretches enriched in proline, glutamine, serine and threonine (PEST) residues which are frequently characteristic of rapidly degraded proteins,<sup>7</sup> a bipartite nuclear localization signal, and a region rich in Arg-Ser (RS)<sup>8</sup> (fig. 3A). RT-PCR analysis revealed a broad tissue expression of *TOPORS* in human tissues, including the retina (fig. 3B).

To examine the effect of disease-associated mutations, we performed immunoblotting of whole lymphoblastoid cell lysates from both families in affected and unaffected individuals using a N-terminus mouse monoclonal *TOPORS* antibody (Abnova, Taiwan). The full-length *TOPORS*-immunoreactive band of 150 kDa is present in the lymphocytes of control and affected individuals, however, the mutations are predicted to delete 221 (~30 kDa) and 175 (~25 kDa) amino acids from the C-terminus of the protein in the French-Canadian and the German families, respectively. As a result the truncated protein is expected to have a theoretical molecular weight of 120-125 kDa. Our analysis did not detect the predicted truncated *TOPORS*-immunoreactive bands in patient lymphocytes, indicating that the mutant protein is relatively unstable (fig. 4). The absence of the truncated protein in patients from both families suggests haplo-insufficiency rather than a dominant negative effect as the molecular basis of the disease.

*TOPORS* was identified initially in a screen of proteins that bind to N-terminus of topoisomerase I and then as a protein that interacts with p53.<sup>6,9</sup> Like other RING domain-containing proteins, *TOPORS* is an E3 ubiquitin ligase with specific E2 enzymes and it can ubiquitinate p53.<sup>10</sup> It also undergoes modification by the small ubiquitin-like modifier SUMO-1.<sup>11</sup> It is located in nuclear speckles that closely associate with PML nuclear bodies, nuclear compartments that have been implicated in transcription, DNA repair, viral defense, stress, cell cycle regulation, proteolysis and apoptosis.<sup>12,13</sup> In *Drosophila* *Topors* (d*Topors*) ubiquitinates and regulates the activity of the transcriptional repressor Hairy.<sup>14</sup> It also interacts with proteins of the gypsy insulator protein complex, where its influence on insulator activity has been shown to depend on its ubiquitin ligase activity.<sup>15</sup>

*TOPORS* contains an Arg-Ser - rich (RS) domain, which is implicated in pre-mRNA splicing. Mutations in three other proteins involved in mRNA splicing (PRPF3, PRPC8 and PRPF31) are also associated with RP.<sup>16-18</sup> By binding to specific sequences on pre-mRNA and interacting with other splicing factors via their RS domain, SR proteins mediate different intraspliceosomal contacts, thereby helping in splice site selection and spliceosome assembly. Binding of SR proteins to exonic (intronic) splicing enhancers (silencers) helps in recruitment of U1 snRNP to the 5' splice site and U2 snRNP to the branch point sequence.<sup>19</sup> However, *TOPORS* nuclear speckles do not co-localise with nuclear splicing speckles that contain other SR-proteins e.g. SC35.<sup>11</sup> A recent genome-wide survey revealed a large complexity of RS-domain-containing proteins in metazoans with functions not only in pre-mRNA splicing but also in chromatin remodelling, transcription by RNA polymerase II, and cell cycle progression.

We therefore predict that TOPORS may not only be involved in mRNA processing but also have a more complex array of functions in mammalian cells.<sup>20</sup>

It is possible that the process underlying *RP31* pathogenesis might be distinct from those operating in other forms of autosomal dominant RP where mutations have previously been identified in structural proteins, transcription and splicing factors. Elucidation of its function in retinal photoreceptors and, more important, studies of its expression in photoreceptors and protein interactions in retina may provide new insight into the molecular basis of retinal degenerations.

Finally as stated earlier, the lack of mutant TOPORS protein in patients in the families reported here, is highly suggestive of haplo-insufficiency as the molecular basis of the disease and therefore makes rescue of the disease phenotype amenable to somatic gene therapy. Should haplo-insufficiency explain the disease mechanism, targeted increase in the level of the wild type protein in photoreceptor cells of patients should lead to rescue of the disease phenotype. Using a viral vector (Adeno-Associated Virus or Lentivirus) mediated gene delivery system and sub-retinal injection, a functional copy of the gene can be delivered under the control of photoreceptor specific promoters to achieve targeted expression in the appropriate cell type. Somatic gene therapy rescue have been achieved in several animal models of retinal degeneration including the rds mouse and may also prove a successful approach in this type of adRP.<sup>21,22</sup>

## **Acknowledgments**

We thank the patients and their families for participating in this study. We thank C. Murga-Zamalloa and Beverly Scott for technical assistance. This work was supported by grants from The Foundation Fighting Blindness, EU grants: EVI-GENORET (LSHG-CT-2005-512036), RETNET (MRTN-CT-2003-504003), Special Trustees of Moorfields Eye Hospital, National Institutes of Health (EY007961, EY007003), Biotechnology and Biological Sciences Research Council, Research to Prevent Blindness, George M. O'Brien Kidney Research Foundation, Foundation Fighting Blindness-Canada and Fonds de la Recherche en Santee du Quebec.

**Web Resource**

The URL for data presented herein is as follows:

Online Mendelian Inheritance in Man (OMIM), <http://www.ncbi.nlm.nih.gov/Omim>

GDB Human Genome Database, <http://gdbwww.gdb.org/> (for marker sequences and conditions)

ENSEMBL Human Genome Browser, <http://www.ensembl.org/> (for marker and gene positions)

UCSC Genome browser, <http://genome.ucsc.edu/> (for marker and gene positions)

RetNet, <http://www.sph.uth.tmc.edu/Retnet/>

## References

1. Rivolta C, Sharon D, DeAngelis MM, Dryja TP (2002) Retinitis pigmentosa and allied diseases: numerous diseases, genes, and inheritance patterns. *Hum Mol Genet* 11:1219–1227
2. Himms MM, Diager SP, Inglehearn CF (2003) Retinitis pigmentosa: genes, proteins and prospects. *Dev Ophthalmol* 37:109-1254
3. Papaioannou M, Chakarova CF, Prescott Q, Waseem N, Theis T, Lopez I, Gill B, Koenekoop RK, Bhattacharya SS (2005) A new locus (RP31) for autosomal dominant retinitis pigmentosa maps to chromosome 9p. *Hum Genet* 118:501-503
4. Sharon D, Yamamoto H, McGee TL, Rabe V, Szerencsei RT, Winkfein RJ, Prinsen CF, Barnes CS, Andreasson S, Fishman GA et al (2002) Mutated alleles of the rod and cone Na-Ca+K-exchanger genes in patients with retinal diseases. *Invest Ophthalmol Vis Sci* 43:1971-1979
5. Antic D, Keene JD (1997) Embryonic lethal abnormal visual RNA-binding proteins involved in growth, differentiation, and posttranscriptional gene expression. *Am J Hum Genet* 61:273-278
6. Haluska P, Saleem A, Rasheed Z, Ahmed F, Su EW, Liu LF, Rubin EH (1999) Interaction between human topoisomerase I and a novel RING finger/arginine-serine protein. *Nucleic Acids Research* 27:2538-2544
7. Weger S, Hammer E, Heilbronn R (2002) Topors, a p53 and topoisomerase I binding protein, interacts with the adeno-associated virus (AAV-2) Rep78/68 proteins and enhances AAV-2 gene expression. *J Gen Virol* 83:511-516
8. Lorick KL, Jensen JP, Fang S, Ong AM, Hatakeyama S, Weissman AM (1999)

RING fingers mediate ubiquitin-conjugating enzyme (E2)-dependent ubiquitination.

Proc Natl Acad Sci USA 96:11364-11369

9. Zhou R, Wen H, Ao SZ (1999) Identification of a novel gene encoding a p53-associated protein. Gene 235:93-101

10. Rajendra R, Malegaonkar D, Pungaliya P, Marshall H, Rasheed Z, Brownell J, Liu LF, Lutzker S, Saleem A, Rubin EH (2004) Topors functions as an E3 ubiquitin ligase with specific E2 enzymes and ubiquitinates p53. J Biol Chem 279:36440-36444

11. Weger S, Hammer E, Engstler M (2003) The DNA topoisomerase I binding protein topors as a novel cellular target for SUMO-1 modification: characterization of domains necessary for subcellular localization and sumolation. Exp Cell Res. 290:13-27

12. Rasheed ZA, Saleem A, Ravee Y, Pandolfi PP, Rubin EH (2002) The topoisomerase I-binding RING protein, topors, is associated with promyelocytic leukemia nuclear bodies. Exp Cell Res 277:152-160

13. Borden KL (2002) Pondering the promyelocytic leukemia protein (PML) puzzle: possible functions for PML nuclear bodies. Mol Cell Biol 22:5259-5269

14. Secombe J, Parkhurst SM (2004) Drosophila Topors is a RING finger-containing protein that functions as a ubiquitin-protein isopeptide ligase for the hairy basic helix-loop-helix repressor protein. J Biol Chem 2004 279:17126-17133

15. Capelson M, Corces VG (2005) The ubiquitin ligase dTopors directs the nuclear organization of a chromatin insulator. Mol Cell 20:105-116

16. Chakarova CF, Hims MM, Bolz H, Abu-Safieh L, Patel RJ, Papaioannou MG, Inglehearn CF, Keen TJ, Willis C, Moore AT et al (2002) Mutations in HPRP3, a third

member of pre-mRNA splicing factor genes, implicated in autosomal dominant retinitis pigmentosa. *Hum Mol Genet* 11:87-92

17. McKie AB, McHale JC, Keen TJ, Tarttelin EE, Goliath R, van Lith-Verhoeven JJ, Greenberg J, Ramesar RS, Hoyng CB, Cremers FP et al (2001) Mutations in the pre-mRNA splicing factor gene *PRPC8* in autosomal dominant retinitis pigmentosa (RP13). *Hum Mol Genet* 10:1555-1562

18. Vithana EN, Abu-Safieh L, Allen MJ, Carey A, Papaioannou M, Chakarova C, Al-Magthteh M, Ebenezer ND, Willis C, Moore AT et al (2001) A human homolog of yeast pre-mRNA splicing gene, *PRP31*, underlies autosomal dominant retinitis pigmentosa on chromosome 19q13.4 (RP11). *Mol Cell* 8:375-381

19. Lorkovic ZJ, Lopato S, Pexa M, Lehner R, Barta A (2004) Interactions of Arabidopsis RS domain containing cyclophilins with SR proteins and U1 and U11 small nuclear ribonucleoprotein-specific proteins suggest their involvement in pre-mRNA Splicing. *J Biol Chem* 279:33890-33898

20. Cazalla D, Newton K, Caceres JF (2005) A novel SR-related protein is required for the second step of Pre-mRNA splicing. *Mol Cell Biol* 25:2969-2980

21. Ali RR, Sarra GM, Stephens C, Alwis MD, Bainbridge JW, Munro PM, Fauser S, Reichel MB, Kinnon C, Hunt DM et al (2000) Restoration of photoreceptor ultrastructure and function in retinal degeneration slow mice by gene therapy. *Nat Genet* 25:306-310

22. Bainbridge JW, Tan MH, Ali RR.(2006) Gene therapy progress and prospects: the eye. *Gene Ther* 13:1191-1197

Table 1. Primers Used for PCR Amplification of *TOPORS* Exons

<i>Exon</i>	<i>Product Size (bp)</i>	<i>Primer Sequence</i>		<i>T (C°)</i>
		<i>Forward</i>	<i>Reverse</i>	
1	628	5'-CGTCAGGTTACCGTTGCC-3'	5'-ATATTGCATTGCAACTAG-3'	57
2	616	5'-GGCTGAGTACCAGTAAC-3'	5'-CACCAATCCACAGGTGCG-3'	61
3a	847	5'-AGTAATGGGTCACTTAAG-3'	5'-AAGAACTGTAAGTTCACG-3'	50
3b	901	5'-ATTCCTCAGTTTATGAGAC-3'	5'-TATCACCAGAACTGTAAG-3'	48
3c	864	5'-CTTCTGACAGTTCAGATG-3'	5'-GAGCTCTGGACAGAGTCC-3'	56
3d	914	5'-TAGCAGTTGGTCCAGAAG-3'	5'-TTGTA ACTACATCTTTAG-3'	57
3e	997	5'-CAGATCAAGGAGCCTGTCTAG-3'	5'-TAAGCTGCTAGCAGTATC-3'	60

## Figure legends

### Figure 1

Color photograph of the right eye of a 10 year old affected child (IV:3). At this age a very obvious and unusual perivascular "cuff" of atrophy (shown with arrows) around the superior and inferior vascular arcades is visible. The optic disc appears normal in color, while the retinal arterioles are narrow, and there was no pigmentary degeneration at this stage. The cuff of RPE atrophy was found in three other children in this family as well, but was not found in the adults of this pedigree. At a later age this feature apparently disappears.

### Figure 2

Pedigree structure and sequence analysis of *TOPORS* mutations. *A and C*, Canadian and German adRP pedigrees used in this study. Affected individuals are shown in black, unaffected are identified by open symbols and deceased individuals are indicated by a slash (/). Asymptomatic individuals are marked by an asterisk. Mutation segregation is shown on the pedigree as +/+ (normal), +/- (affected). *B*, Electropherogram of the heterozygous mutation, c.2474\_2475insA (p.Tyr825fs), in exon 3 of the *TOPORS* gene found in the Canadian family. *D*, Electropherogram of the heterozygous mutation found in the German family, c.2552\_2553delGA (p.Arg851fs). Both mutations were identified after cloning of the amplified PCR product into pGEMT-Easy vector (Promega).

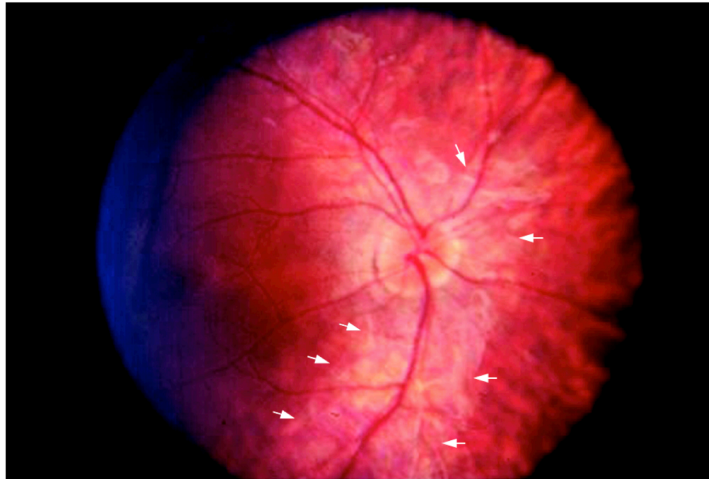
### Figure 3

Chromosomal location, domain organization and expression of *TOPORS*. *A*, Schematic representation of exon-intron structure of *TOPORS* and domain structure of its protein: RING-type zinc finger domain; SR domain: Serine-Arginine rich domain; NLS: Nuclear Localization Signal; Lysine-Histidine domain; PEST - Proline, Glutamic acid, Serine, and Threonine rich region; N- amino-terminal; C- Carboxyl-terminal. Both mutations (p.Tyr825fs and p.Arg851fs) are shown with asterisks. *B*, RT-PCR analysis of *TOPORS* transcript in human tissues: PCR was carried out with primers selected from exon 3 (28 cycles). A band of 2.69 kb was observed in all of the tested QUICK-Clone cDNAs (Clontech) from retina, brain, kidney, liver, heart, skeletal muscle, pancreas, lung and placenta. A ubiquitously expressed gene, *PGM1*, was used as a control.

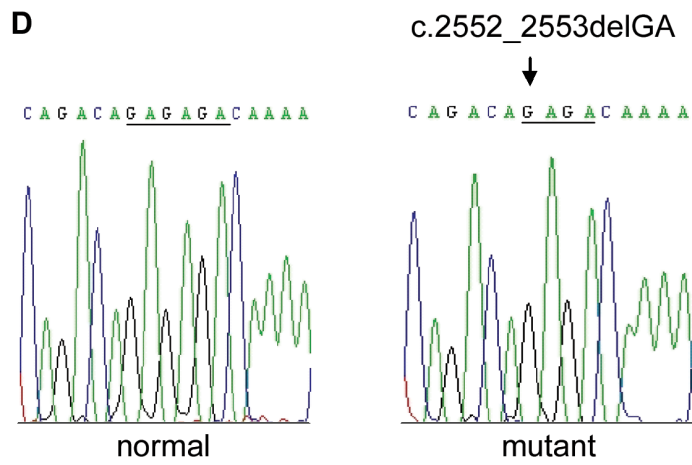
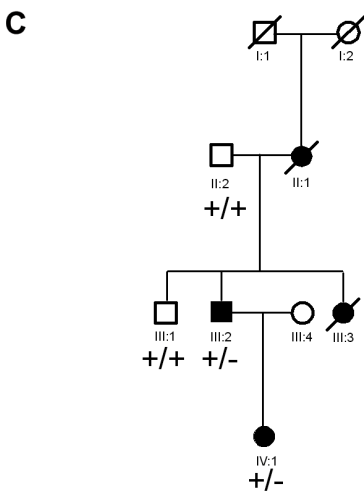
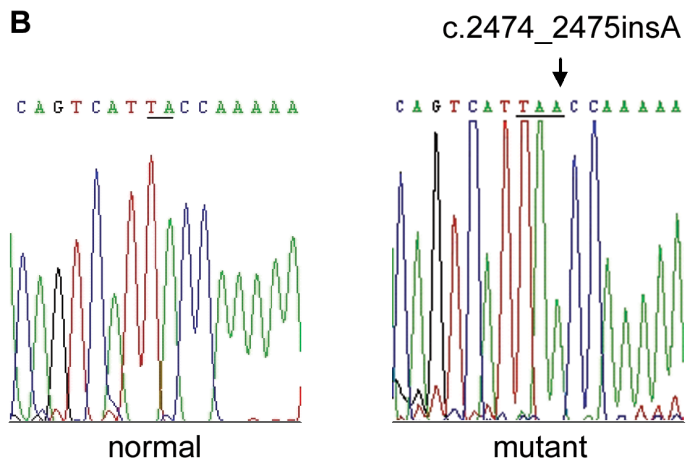
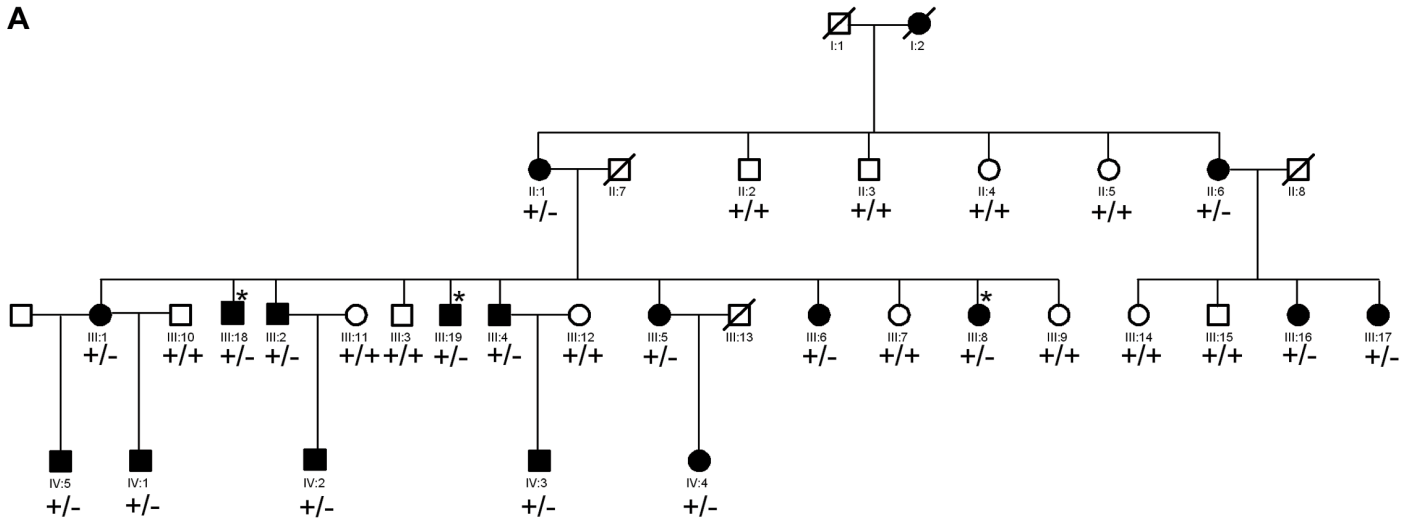
### Figure 4

*TOPORS* expression in patient lymphoblastoid cell lines. Protein extracts from cell lines from one unaffected and two affected individuals from the Canadian and the German family with p.Tyr825fs and p.Arg851fs mutations respectively were analyzed by SDS-PAGE and immunoblotting using anti-*TOPORS* antibody (Abnova).  $\alpha$ -tubulin was used as a control.

**Figure 1**

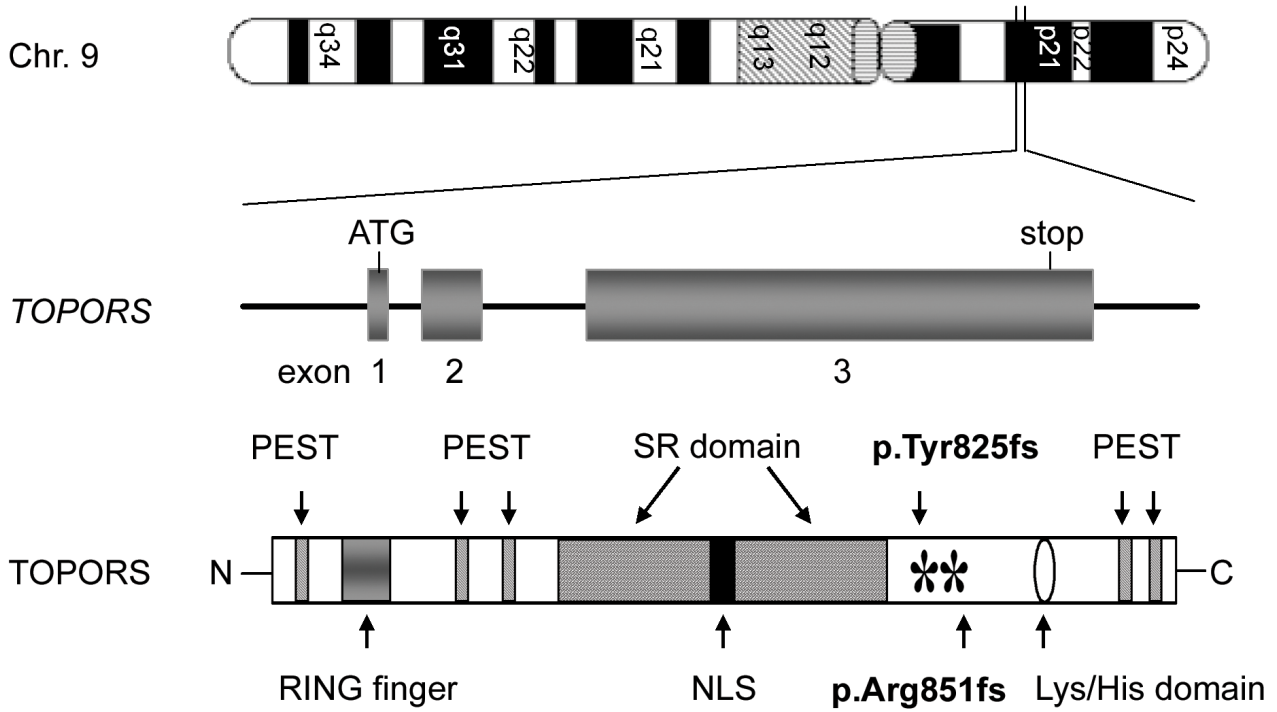


**Figure 2**

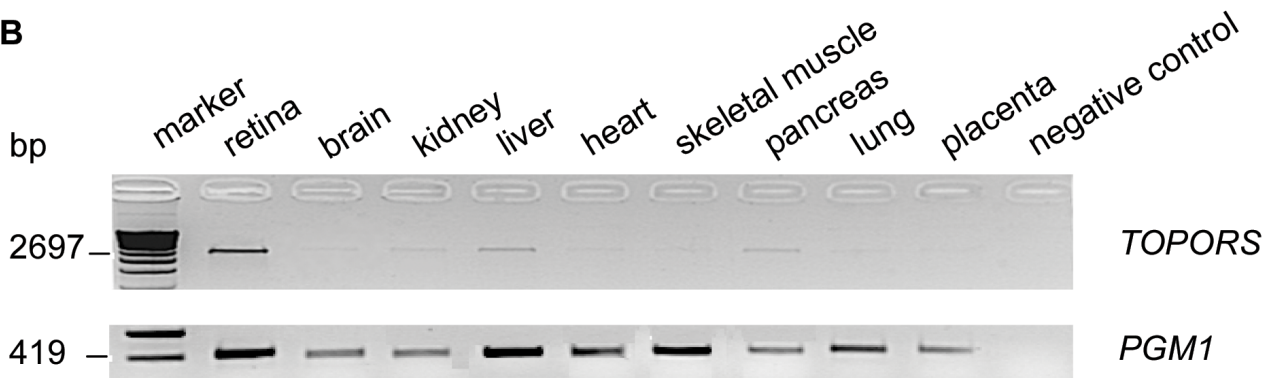


**Figure 3**

**A**



**B**



**Figure 4**

