

Università degli studi di Modena e Reggio Emilia

Dipartimento di Scienze Fisiche, Informatiche e Matematiche

Dottorato in Matematica

In convenzione con l'Università degli Studi di Ferrara e
l'Università degli Studi di Parma.

XXXIV ciclo.

Even Cycle decompositions of index 3 in 4-regular line graphs

Candidato:

Maria Chiara Molinari

Matricola 251377

Relatore:

Prof.ssa

Simona Bonvicini

Coordinatore del Dottorato:

Prof.

Cristian Giardinà

Anno accademico 2020-2021

Contents

Introduction	3
1 The palette index of a graph	7
2 Even cycle decompositions	13
2.1 On the index of an even cycle decomposition	19
3 A novel coloring technique	27
4 The main construction	35
5 Cubic graphs of arbitrary large oddness	49
6 Final Remarks	63
Bibliography	64

CONTENTS

Introduction

A classical result by Veblen [30] states that a graph is Eulerian if and only if it has a cycle decomposition, that is, a partition of the edge set into cycles. Each Euler tour in the graph defines an arbitrary cycle decomposition that does not necessarily satisfy further conditions as, for instance, on the length of the cycles. As we will remark in Chapter 2, cycle decompositions meeting additional conditions might be related to some hard problems in graph theory. We consider decompositions into cycles of even length - *even cycle decompositions*, briefly *ECD* - whose cycles can be colored by m distinct colors so as two cycles sharing at least one vertex receive distinct colors. If m is the minimum number of required colors, then we say that the even cycle decomposition has index m . The notion of an *ECD* of index m is connected to the palette index of a graph, a chromatic parameter describing a graph by the minimum number of palettes of its vertices [15]. In Chapter 1, we describe the palette index of a graph in detail and survey some results. In particular, the possible values for the palette index of a 4-regular graph are 1, 3, 4 and 5 [7]. The results in [7] shows that it is 3 if and only if the graph has an even 2-factor - a 2-factor with no odd cycle - or an *ECD* of index 3. There exist infinite families of 4-regular graphs with an *ECD* of index 3 [4]. As far as we know, no example of 4-regular graph having *ECDs* and palette index larger than 3 is known. Equivalently, no example of 4-regular graph whose edge set can be partitioned into even cycles and every *ECDs* has index larger than 3 is known. Motivated by the problem on the existence of such a 4-regular graph, in this thesis we pursue the study of *ECDs* in 4-regular

line graphs of class 2 cubic graphs that started in [4]. We recall here that the line graph of a graph G is the graph $L(G)$ whose vertices correspond to the edges of G ; and two vertices are adjacent if the corresponding edges are incident in G . As pointed out in Chapter 2, 4-regular line graphs of class 2 cubic graphs are an interesting family of class 2 graphs since they are related to some famous conjectures. In [24] it is conjectured that the line graph of a bridgeless cubic graph has an ECD ; and the conjecture is proved for the line graph of a bridgeless cubic graph with a chordless 2-factor. In [21] it is proved for the line graph of a bridgeless cubic graph of oddness 2 and 4. The oddness of a cubic graph G measures the uncolorability of G and is defined as the minimum number of odd cycles in a 2-factor of G taken over the set of all possible 2-factors of G . The methods used in [21, 24] for the construction of an ECD in the line graph of a cubic graph G do not provide the ECD of $L(G)$ with the smallest index. In fact, for some cubic graphs G we find an ECD of index $m > 3$ even though we know that $L(G)$ has an ECD of index 3. The construction in [8] about the existence of an ECD of index 3 in the line graph of a cubic graph of oddness 2 is alternative to the proof in [21] about the existence of an arbitrary ECD . The new results on the line graphs of class 2 cubic graphs with arbitrary large oddness, that are proved in [8] and in this thesis, give evidence to the conjecture in [24] and a contribution to the more general problem on the existence of ECD s in Eulerian graphs. This last problem is widely studied in the literature. As far as we know, the existence of ECD s has been proved for 2-connected Eulerian planar graphs of even size [27]; for 2-connected Eulerian graphs of even size containing no subgraph contractible to K_5 [32].

Nevertheless, the result in [32] does not resolve the existence problem for 4-regular graphs since almost all 4-regular graphs have a K_5 -minor [23].

We specify that the graphs considered in this thesis are simple, unless otherwise stated. We refer to [3] for graph theory notation and terminology which is not explicitly expressed. In particular, the length $l(P)$ of a path P is the number of edges of P ; a path is even or odd according to whether its

length is even or odd, respectively. For a path P with endvertices x, y we will also use the notation xPy and yPx for the reversed path. We denote by M_C the subset of a perfect matching M of G consisting of the edges that are incident to the vertices in C , where C is a cycle in $G - M$. The subset of the vertex-set of $L(G)$ consisting of the vertices v_e corresponding to the edges e in C (M_C will be denoted by $L(C \cup M_C)$).

The thesis consists of five chapters. Chapter 1 is devoted to the study of the palette index and the results that give rise to the problem studied in this thesis. Chapter 2 shows the state of art on the existence of even cycle decompositions in 4-regular (line) graphs. In Chapter 3, we describe the (novel) coloring technique introduced in [8] on the edges of $L(G)$ that transforms each odd cycle belonging to a cycle decomposition of $L(G)$ into one path of odd length together with a pattern of even paths (see for instance Figure 3.1). By this technique, in Chapter 4 and 5 we adapt the construction introduced in [8] and we find an *ECD* of index 3 in the line graph of a cubic graph having arbitrary large oddness. The cubic graphs belong to infinite families that are known in the literature. Some of these results are proved in [8], some others are new.

INTRODUCTION

Chapter 1

The palette index of a graph

The palette index of a graph is a chromatic parameter depending on the edge-colorings of the graph. We survey some results on the parameter showing that it provides some information about the structure of the graph, as for instance the existence of 1-factors, even 2-factors, a partition of the edge set into even cycles. The results we show are related to the problem we are considering.

A *k*-edge-coloring of a graph G is an assignment f of k distinct colors to the edges of G . It is proper if no two adjacent edges receive the same color. The *chromatic index* of a graph G is defined as the minimum integer k such that G has a k edge-coloring and is denoted by $\chi'(G)$. By Vizing's theorem [31], the number of colors needed to color the edges of a simple graph G is either its maximum degree $\Delta(G)$ or $\Delta(G) + 1$. A graph is *class 1* or *class 2* according to whether $\chi'(G)$ is $\Delta(G)$ or $\Delta(G) + 1$, respectively. The decision problem whether a graph is class 2 is an *NP*-complete problem [13].

For a proper edge-coloring f of a graph G , we denote by $P_f(v)$ the set of colors assigned by f to the edges incident to v ; the set $P_f(v)$ is called the *palette* of the vertex v (with respect to f).

We denote by \mathcal{P}_f the set of distinct palettes of the vertices in $V(G)$, that is, $\mathcal{P}_f = \{P_f(v) : v \in V(G)\}$. The minimum number of distinct palettes taken over the set of all proper edge-colorings of G is the *palette index* of G and is denoted by $\check{s}(G)$.

Example 1.0.1. The Figure 1.1 shows a 4-regular graph whose edges are colored according to the proper edge-coloring $f : E(G) \rightarrow \{a_1, a_2, a_3, a_4\}$ as follows: $f(u_1u_4) = f(u_2u_5) = f(u_3u_6) = a_1$, $f(u_1u_2) = f(u_3u_4) = f(u_5u_6) = a_2$, $f(u_1u_3) = f(u_2u_6) = f(u_4u_5) = a_3$, $f(u_1u_5) = f(u_2u_3) = f(u_4u_6) = a_4$. We find exactly one palette, namely $P_f(u_i) = \{a_1, a_2, a_3, a_4\}$ for $i = \{1, 2, 3, 4, 5, 6\}$, whence $\check{s}(G) = 1$.

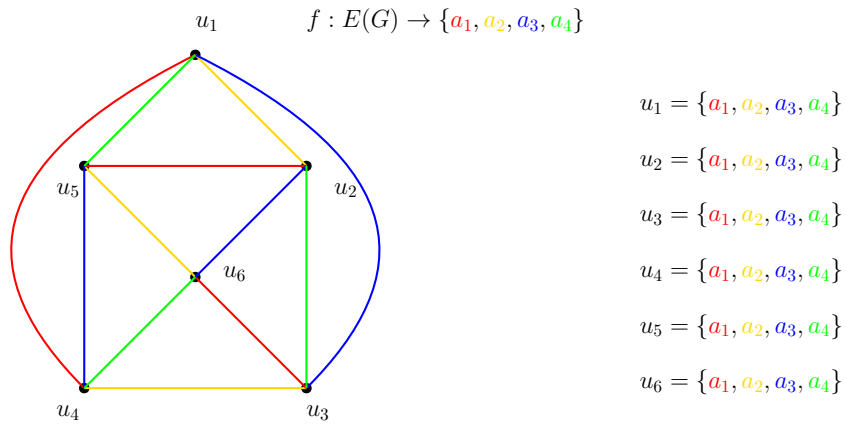

$$\check{s}(G) = |\{a_1, a_2, a_3, a_4\}| = 1$$

Figure 1.1: A 4-edge-coloring of a 4-regular graph G with exactly one palette $\{a_1, a_2, a_3, a_4\}$ for each vertex of the graph.

As far as we know, the palette index has been introduced in [15]; in the same paper, the exact value of $\check{s}(G)$ is determined for complete and 3-regular graphs G . The parameter is studied for several other families: complete bipartite graphs [14]; trees [5]; 4-regular graphs [7]; and many others [1, 9, 11, 14, 28].

A generalization of the palette index can be found in [6], where the multi-palette index of a graph G is defined as the minimum number of distinct multi-palettes taken over the set of all edge-colorings of G ; and it is used for studying the self-assembly of DNA molecules. Unlike the palette index, the colorings may not be proper; and the multi-palettes may be multi-sets.

As proved in [15], the palette index of a d -regular graph is different from 2 and is 1 if and only if the graph is class 1; it is at most $d + 1$ as remarked in [15]. In fact by Vizing' Theorem a d -regular graph G of class 2 has a proper $(d + 1)$ -edge-coloring f ; since each palette is a d -subset of colors, the cardinality of \mathcal{P}_f is at most $\binom{d+1}{d}$ whence $\check{s}(G) \leq d + 1$. Therefore, the palette index of a d -regular graph of class 2 satisfies the following inequalities:

$$3 \leq \check{s}(G) \leq d + 1.$$

As for the small values of d , $d \leq 4$, the following results hold. For a 2-regular graph G , the palette index is 1 if and only if the graph is class 1; otherwise $\check{s}(G) = 3$. More specifically, if every connected components is an even cycle, then we can color alternately every cycle by a pair of colors, say a_1, a_2 , and find exactly one palette, namely $\{a_1, a_2\}$. If G contains a cycle C of odd length, then we can color the edges of C by three distinct colors, say a_1, a_2, a_3 , so as to find the palettes $\{a_1, a_2\}, \{a_2, a_3\}, \{a_1, a_3\}$.

As an example, the graph G_1 in Figure 1.2(a) has palette index 1 since every cycle has even length; the graph G_2 in Figure 1.2(b) has palette index 3 since it contains a cycle of odd length.

By the results in [15], the palette index of a 3-regular graph of class 2 is 3 or 4 according to whether G has a 1-factor or not, respectively.

By the inequalities $3 \leq \check{s}(G) \leq d + 1$, the palette index of a 4-regular graph of class 2 is 3, 4 or 5. The results in [7] show that for each of these values, there exists a 4-regular graph with palette index 3, 4 or 5.

In particular, by Proposition 1 in [7] the edges of a 4-regular graph G with palette index 3 can be colored according the 5- or a 6-edge coloring, f_1, f_2 , respectively.

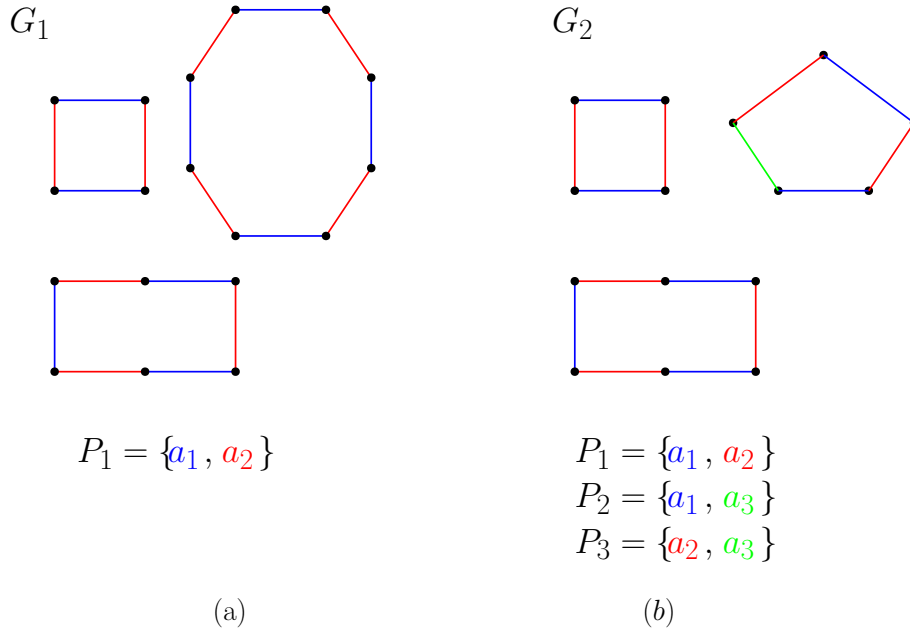

Figure 1.2: (a) A 2-regular graph with palette index 1; (b) A 2-regular graph with palette index 3.

The coloring f_1 , has color-set $\{a_1, a_2, a_3, a_4, a_5\}$ and palettes $P_1 = \{a_1, a_2, a_3, a_4\}$, $P_2 = \{a_1, a_2, a_3, a_5\}$, $P_3 = \{a_1, a_2, a_4, a_5\}$.

The coloring f_2 , has color-set $\{a_1, a_2, a_3, a_4, a_5, a_6\}$ and palettes $P_1 = \{a_1, a_2, a_3, a_4\}$, $P_2 = \{a_1, a_2, a_5, a_6\}$, $P_3 = \{a_3, a_4, a_5, a_6\}$.

By Corollary 1 in [7] a graph G that can be colored according to f_1 has an even 2-factor (a 2-factor with no odd cycles) which is induced by the edges having color a_1 and a_2 .

The edge set of a graph G that can be colored according to f_2 can be partitioned into three 2-regular subgraphs whose connected components are cycles of even length; each 2-regular subgraph is induced by the edges having the following pairs of colors: $\{a_1, a_2\}$, $\{a_3, a_4\}$ and $\{a_5, a_6\}$.

Such a partition is equivalent to a partition of the edge set of G into even cycles whose cycles satisfy the following property: they can be colored by 3 distinct colors so as cycles sharing a vertex receive distinct colors. Decom-

positions of this type will be called *even cycle decompositions of index 3* and will be discussed in more detail in the next chapter.

As remarked in [7], there exist 4-regular graphs whose edge set can be colored according to both edge-colorings, f_1 and f_2 ; there also exist 4-regular graphs admitting just one of the colorings f_1, f_2 .

Example 1.0.2. The 4-regular graph G of class 2 with palette index 3 in Figure 1.3 admits both colorings f_1 and f_2 ; the graph G has an even 2-factor consisting of the cycles $(v_1, v_2, v_6, v_5, v_1)$ and $(v_0, v_4, v_3, w_3, w_4, w_5, w_6, w_2, w_1, w_0, v_0)$; the graph G also has an even cycle decomposition given by the cycles $F_1 = \{(v_0, v_4, v_5, v_6, v_0), (w_0, w_4, w_5, w_6, w_0)\}$, $F_2 = \{(v_1, v_5, v_3, v_2, v_1), (w_1, w_6, w_2, w_4, w_3, w_5, w_1)\}$, $F_3 = \{(v_0, w_0, w_1, w_2, w_3, v_3, v_4, v_2, v_6, v_1, v_0)\}$.

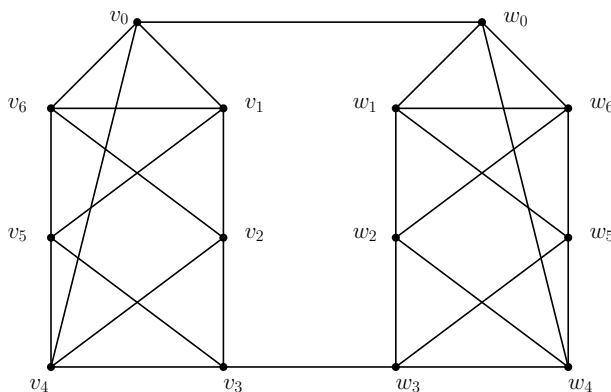

Figure 1.3: The 4-regular graph G in Example 1.0.2 described in [7]; the graph has palette index 3 and admits both colorings f_1, f_2 .

Example 1.0.3. The 4-regular graph G of class 2 with palette index 3 in Figure 1.4 admits the coloring f_1 and has no even cycle decomposition, since it has blocks with an odd number of edges.

The 4-regular graphs with palette index 4 and 5 found so far have no even cycle decomposition. As already remarked, we wonder whether there exists a 4-regular graph with palette index larger than 3 and having an even cycle decomposition. If such a graph exists, then the index of the even

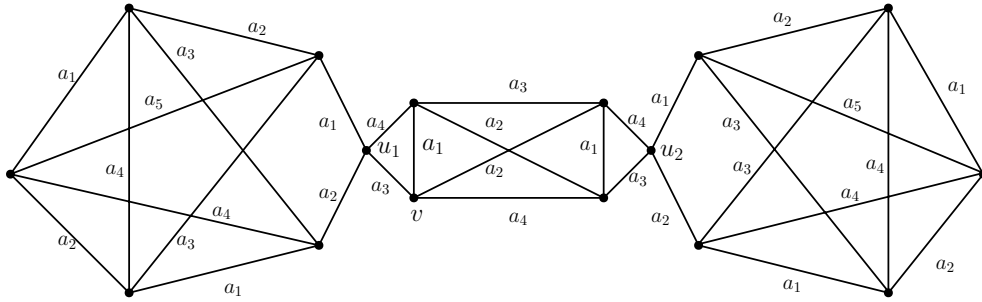

Figure 1.4: The 4-regular graph G in Example 1.0.3 described in [7]; the graph has palette index 3 and admits only the coloring f_1 .

cycle decomposition is necessary larger than 3 (otherwise the palette index is smaller than or equal to 3). Therefore, this is equivalent to investigate about the existence of a 4-regular graph whose edge set can be partitioned into even cycles and every even cycle decomposition has index larger than 3.

Chapter 2

Even cycle decompositions

A *cycle decomposition* of a graph G is a partition of edge set of G into cycles (connected 2-regular subgraphs). It is clear that if a graph has a cycle decomposition then every vertex has even degree. The well-known Veblen's Theorem [30] proves that the converse is also true for Eulerian graphs.

Theorem 2.0.1. (Veblen, [30]) A connected graph G is Eulerian if and only if its edge set can be decomposed into cycles.

Proof. Let G be a connected graph having a decomposition into cycles. If k cycles are incident at a vertex v of G , then v has degree $2k$. Hence every vertex of G has even degree, that is, G is Eulerian.

Conversely, let G be Eulerian. We show that G can be decomposed into cycles by induction on the number of edges. Since every vertex v of G has even degree $d(v) \geq 2$, the graph G has a cycle C . By removing the edges of C from G we obtain a graph G' whose connected components H_1, H_2, \dots, H_m are Eulerian. By the induction hypothesis, each H_i , $1 \leq i \leq m$, is a disjoint union of cycles that together with C provide a cycle decomposition of G .

■

The existence of an arbitrary cycle decomposition in any Eulerian graph

is easy to prove as Veblen's Theorem shows. However, cycle decompositions satisfying further conditions -as for instance on the length of the cycles - may be connected to some of the hardest problems in graph theory, see [10, 17, 18]. The problem we consider deals with even cycle decompositions of Eulerian graphs which are widely studied in the literature [2, 4, 7, 10, 17, 24, 21, 27]. An even cycle decomposition of a graph G , briefly *ECD*, is a decomposition of G into cycles of even length.

A necessary condition for the existence of an even cycle decomposition of a graph G is that each vertex has even degree; G has an even number of edges; and every block is even. We recall that a block of a graph is a maximal 2-connected subgraph; it is even or odd according to whether the number of edges is even or odd, respectively.

For a planar graph, the necessary conditions are also sufficient, this result dates back to 1981 and is due to Seymour [27].

Theorem 2.0.2. (Seymour [27]) Let G be a planar graph. Then G has an even cycle decomposition if and only if G is Eulerian and has no odd block.

In [32] Zhang generalized the Theorem of Seymour to graphs containing no K_5 -minor.

Theorem 2.0.3. (Zhang [32]) Let G be an Eulerian graph containing no K_5 -minor and containing no odd block. Then G has an even cycle decomposition.

Unfortunately, we cannot use Zhang's result for proving the existence of an *ECD* in a 4-regular graph since almost all 4-regular graphs have a K_5 -minor [23].

Therefore, it is quite natural to wonder whether an arbitrary 4-regular graph has an *ECD*. A positive answer in this direction is given by the following theorem.

Theorem 2.0.4. (Kim, [19]) A random 4-regular graph asymptotically almost surely decomposes into two Hamiltonian cycles.

By Kim's Theorem, a random 4-regular graph of even order asymptotically almost surely has an *ECD* consisting of exactly two even cycle, that is, the graph is class 1. As for 4-regular graphs of odd order, the following conjecture claims that a random 4-regular graph of odd order asymptotically almost surely has an *ECD* consisting of exactly three even cycles.

Conjecture 2.0.5. (Markström, [24]) A random 4-regular graph on $2n + 1$ vertices asymptotically almost surely has a decomposition into one cycle of length $2n$ and two other even cycles.

In [24] it is also conjectured the existence of an *ECD* in 4-regular line graphs. These graphs have connections to well-known problems in graph theory, as for instance the cycle cover of cubic graphs [9, 16]; or Thomassen's conjecture [29] on the existence of a Hamiltonian cycle in a 4-connected line graph.

We recall that the line graph of a graph G is the graph $L(G)$ whose vertices correspond to the edges of G ; and two vertices of $L(G)$ are adjacent if the corresponding edges of G are incident. Hence, the line graph of a cubic graph is a 4-regular graph.

Conjecture 2.0.6. (Markström, [24]) If G is a 2-connected cubic graph then $L(G)$ has an *ECD*.

Conjecture 2.0.6 is true for the line graph of a class 1 cubic graph, as remarked in [4, 24].

It has also been verified for the line graph of class 2 cubic graphs of order up to 36, see [2]. Even the results in [4] give evidence to the conjecture by proving the existence of an *ECD* for the line graph of some class 2 cubic graphs including the Petersen graph, the flowers snarks, the Zamfirescu snark, the Blanuša snarks, the Goldberg snarks, the Loupekine snarks, the double star, the Szekeres snark, the Descartes snark, the Celmins-Swart snarks, the Watkins snark and others.

The existence of an *ECD* is also known for the line graph of class 2 cubic graphs of oddness at most 4, see [21, 24]. For our purposes, we recall the theorems in [24] and [21] stating the existence of an *ECD* together with the proof of the result in [24].

We recall that the oddness of a cubic graph G , denoted by $\omega(G)$, is the smallest number of odd cycles in a 2-factor of G , see [16]. It measures how far is a cubic graph from being 3-edge-colorable. It is easy to see that a cubic graph is class 1 if and only if its oddness is 0.

A chordless 2-factor is a 2-factor consisting of only induced cycles.

Theorem 2.0.7. (Markström, [24]) If G is a 2-connected cubic graph, having a chordless 2-factor, with $\omega(G) = 2$, then $L(G)$ has an *ECD*.

Proof. Let $F = \{C^1, \dots, C^k\}$ be a 2-factor with only two odd cycles, where C^1 and C^2 are the odd cycles. Since G is a 2-connected graph, we can find two vertex-disjoint paths P_1 and P_2 , each with exactly one vertex in C^1 and one in C^2 . We also assume that P_1 and P_2 have been chosen such that the intersection of a path with any cycle C is a path. Since a cycle is connected this is always possible.

Let A_1 and A_2 be the two vertex-disjoint paths in C^1 joining the endpoints of P_1 and P_2 . Since C^1 is odd, exactly one of A_1 and A_2 must have odd length, we may assume that it is A_1 .

Let p_1 be the path formed by A_1 and the first edge of P_1 and P_2 . Let p_2 be the path formed by A_2 and the same edges from P_1 and P_2 .

We will now use p_1 and p_2 to construct a covering, by paths and cycles, of P_1 and P_2 such that the edges are covered twice if they belong to $(P_1 \cup P_2) \setminus F$, once if they belong to C , and each cycle in the covering is even. We will do this by following both paths from C^1 to C^2 in parallel and extend the graphs p_1 and p_2 appropriately. In all the following figures we imagine that the paths are going from left to right towards C^2 . If only one of P_1 and P_2 intersects a cycle $C^i, i \geq 3$ from F then we route the two paths p_1 and p_2 through C as shown in Figure 2.1.

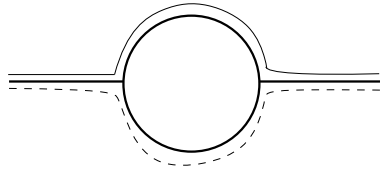

Figure 2.1: A simple intersection

If both P_1 and P_2 intersect $C^i, i \geq 3$ then there are two possible configurations, shown in Figure 2.2. In the situation depicted in Figure 2.2(left), both p_1 and p_2 are routed past C^i , and since C^i has even length exactly one of them will have odd length after doing so, even though we do not know which one might have changed.

In the situation depicted in Figure 2.2 (right) one of the incoming paths p_1 and p_2 is closed to form a cycle. If the left path from u to v in C^i has odd length we choose to close one of the p_i 's which has odd length, otherwise we close the even one, thereby forming an even cycle. In those situations we then continue to the right with a new path in place of the one we close. Since C^i has even length exactly one of the two continuing paths will have odd length.

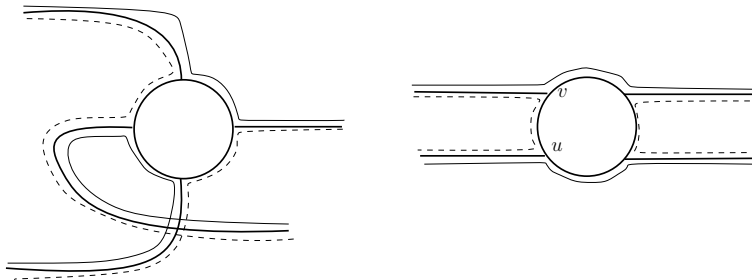

Figure 2.2: The first kind of double intersection (left). The second kind of double intersection. The two edges on the left belong to the incoming paths (right).

When two paths p_1 and p_2 reach C^2 we use the two paths in C^2 between the endpoint of P_1 and P_2 to closed them off into cycles. Since C^2 has odd

length, exactly one of the two paths within C^2 has odd length so we can ensure that both the cycles now formed are even. Call this family of cycles D_0 . Given a cycle C in G we say that there are two cycles in $L(G)$ associated with C . One cycle C' whose vertices are consecutive edges in C , and one cycle C'' whose vertices are alternatingly edges incident with C , but not in C , and edges in C . An example is shown in Figure 2.3. Note that C'' is twice as long as C and hence always an even cycle. We are now ready to construct

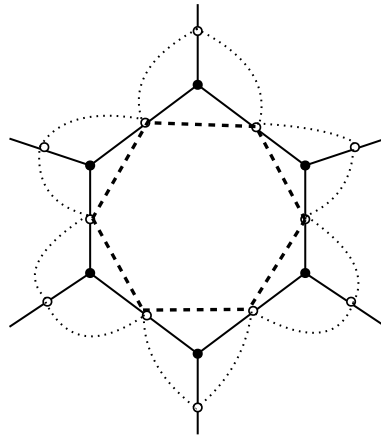

Figure 2.3: The cycles associated with C for a 6-cycle. C' with dashed edges and C'' with dotted edges.

the

$$ECD$$

of $L(G)$. Given the 2-factor F we get a cycle decomposition D_1 by taking the associated cycles for all cycles in C , however C'_1 and C'_2 are odd. We now delete C'_i from D_1 , for all i , to form D_2 . At each edge of $(P_1 \cup P_2) \setminus E(F)$ we modify each C'' in D_2 to instead use an edge of a C' . This does not change the parity of the cycle lengths, since each P_i is incident with two or zero such edges in C . This gives us a collection D_3 of even cycles. Finally, we form our ECD D by including all cycles C' for $C \in D_0$. ■

Theorem 2.0.8. (Liu, You and Cui, [21]) If G is a 2-connected cubic graph

with $\omega(G) \leq 4$, then $L(G)$ has an *ECD*.

Clearly, Theorem 2.0.8 is an improvement of Theorem 2.0.7 as it extends the existence of an *ECD* to the line graph of cubic graphs of oddness at most 4 and it does not require the assumption on the chordless 2-factor.

2.1 On the index of an even cycle decomposition

Given an even cycle decomposition \mathcal{E} of an Eulerian graph G , we color the cycles of \mathcal{E} by m distinct colors so as every pair of cycles sharing at least one vertex receive distinct colors. If m is the minimum number of colors that are required in such a coloring, then we say that \mathcal{E} is an *even cycle decomposition of index m* .

Clearly, any coloring of the elements of \mathcal{E} partitions the edge set of G into 2-regular subgraphs whose connected components are even cycles.

Notice that every $2d$ -regular graph G of class 1 has an *ECD* of index d : we can partition the edge set of G into $2d$ perfect matchings; and join in pairs the matchings so as we find d spanning 2-regular subgraphs whose connected components are even cycles.

The converse is also true. Therefore, a $2d$ -regular graph has an *ECD* of index d if and only if the graph is class 1.

We study even cycle decompositions of 4-regular graphs. By the previous remarks, every 4-regular graph of class 1 has an *ECD* of index 2; and every *ECD* of a 4-regular graph of class 2 has index at least 3.

As remarked in Chapter 1, it is an open problem to determine whether there

exists a 4-regular graph whose edgeset can be partitioned into even cycles and every *ECD* has index larger than 3.

By the known results, the problem seems to be hard. In fact, the study of the palette index of 4-regular graphs in [7] provides several examples of 4-regular graphs of class 2 having an *ECD* of index 3. In [4] the authors give a sufficient condition for the existence of an *ECD* of index 3 in the line graph of a cubic graph; the condition holds for the line graph of several infinite families of class 2 cubic graphs (see the graphs listed in the previous subsection). By Theorem 2.0.4, we also know that a random 4-regular graph asymptotically almost surely has an *ECD* of index 2. The results in [8] show the existence of an *ECD* of index 3 for the line graph of every cubic graph of oddness 2 and for the line graph of some infinite families of cubic graphs having arbitrary large oddness; this thesis deals with these last graphs and other new infinite families (see Chapter 5). Finally, we notice that if Conjecture 2.0.6 is true then a random 4-regular graph of odd order asymptotically almost surely has an *ECD* of index 3.

As for the result in [21, 24], the following example shows that the proof of Theorem 2.0.7 does not construct an *ECD* of index 3 for the line graph of a cubic graph although the graph $L(G)$ has one. Similar comments apply to the constructions in [21].

Example 2.1.1. The Petersen graph G in Figure 2.4 has a 2-factor F consisting of the 5-cycles B^1, B^2 . We apply the proof of Theorem 2.0.7 to G and show that it provides an *ECD* of $L(G)$ having index larger than 3. On the other hand, by Example 12 in [4] we also know that the line graph of the Petersen graph admits an *ECD* of index 3.

According to the proof of Theorem 2.0.7, the paths $P_1, P_2, A_1, A_2, p_1, p_2$ are the following: $P_1 = (v_1, v_6)$, $P_2 = (v_4, v_7)$, $A_1 = (v_1, v_2, v_3, v_4)$, $A_2 = (v_4, v_5, v_1)$, $p_1 = (v_6, v_1, v_2, v_3, v_4, v_7)$ and $p_2 = (v_6, v_1, v_5, v_4, v_7)$. The families of cycles D_0, D_3 are represented in Figure 2.5, 2.6: D_0 consists of two even cycles of length 8 and 6; D_3 consists of two even cycles of length 8.

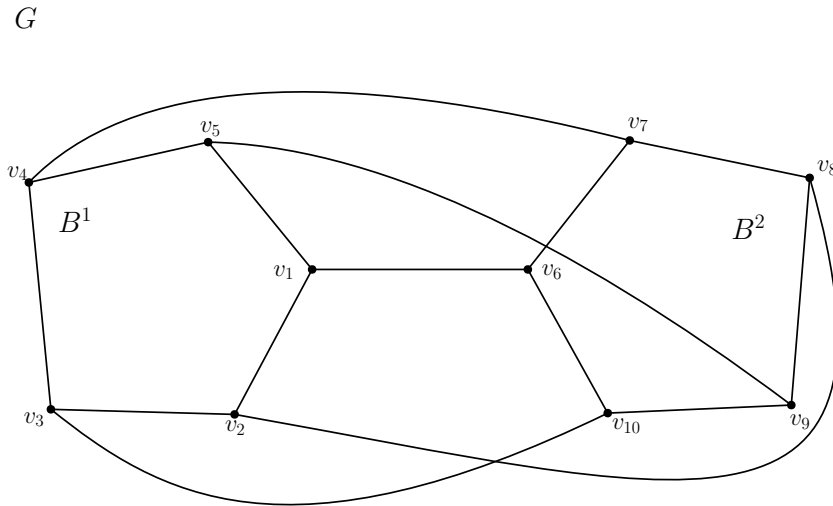

Figure 2.4: The Petersen graph G in Example 2.1.1 has a 2-factor F consisting of the 5-cycles B^1, B^2 .

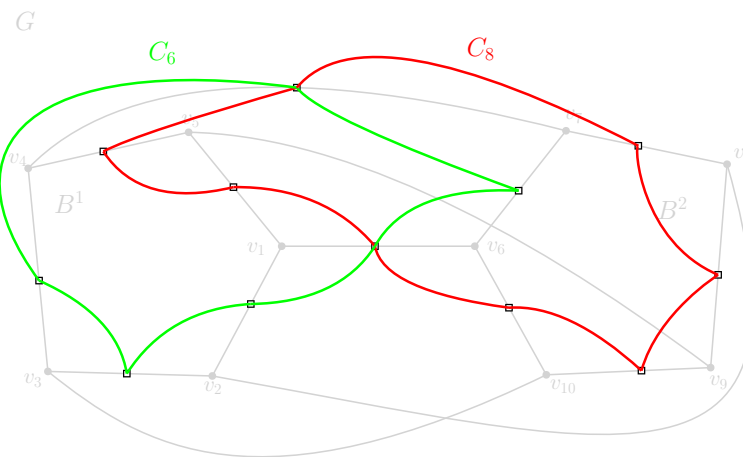

Figure 2.5: The even cycles of $L(G)$ in Example 2.1.1 that can be obtained from the even cycles of G in $D_0 = \{C_8, C_6\}$; the even cycles can be partitioned into two colored classes, say red and green.

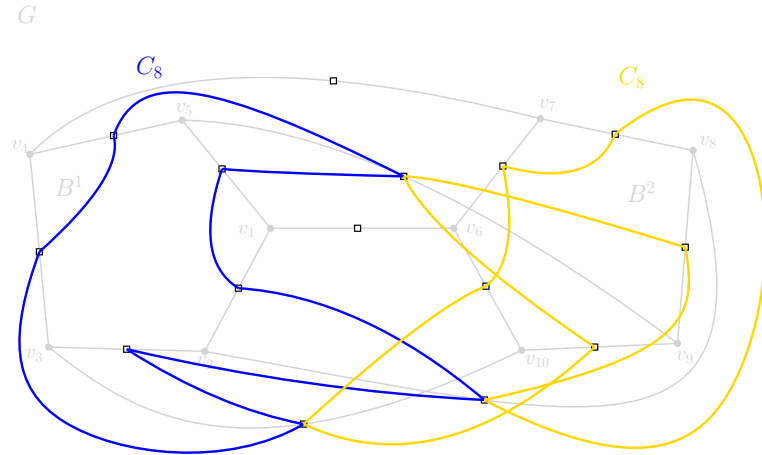

Figure 2.6: The even cycles of $L(G)$ in Example 2.1.1 that can be obtained from the two 8-cycles of D_3 ; the even cycles can be partitioned into two colored classes, say blue and orange.

The cycles in D_0 and D_3 form an *ECD* of $L(G)$ of index 4 (see Figure 2.7).

In the following we show that the line graph of the Petersen graph has an *ECD* of index 3. It is obtained from Fig. 7 in [4] as follows: from the first pair of oriented graphs $H_{1,1}$ and $H_{1,2}$ we construct an edge of $L(G)$ from each pair of arcs entering a vertex; the orientation $H_{1,1}$ gives a matching of cardinality 6; the same for the orientation $H_{1,2}$; the union of the two matchings is an even cycle of the line graph, Figure 2.8. The same is true for the second pair of oriented graphs $H_{2,1}$ and $H_{2,2}$, Figure 2.9. The orientations of the last pair of graphs $H_{3,1}$ and $H_{3,2}$ give each a matching of cardinality 3, Figure 2.10.

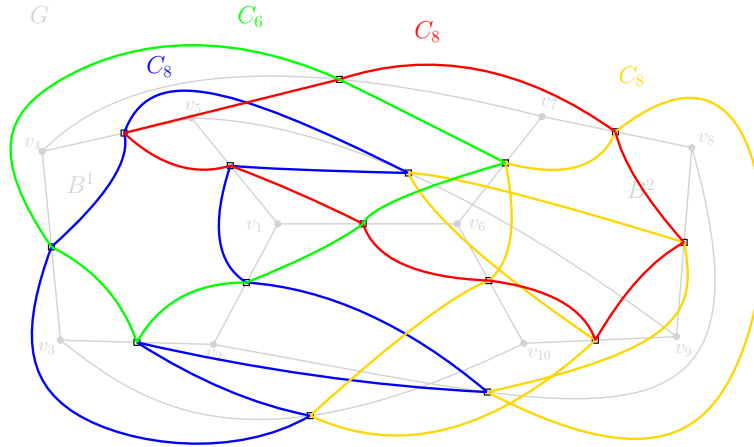

Figure 2.7: The even cycle decomposition of $L(G)$, where G is the Petersen graph, obtained from Theorem 2.0.7; the decomposition has index 4.

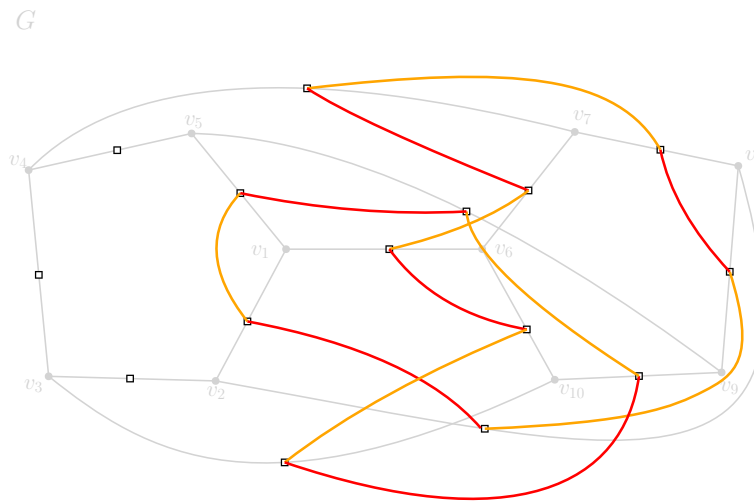

Figure 2.8: The matchings of $L(G)$ obtained from the orientations $H_{1,1}$ and $H_{1,2}$ of Proposition 11 in [4] in red and orange, respectively.

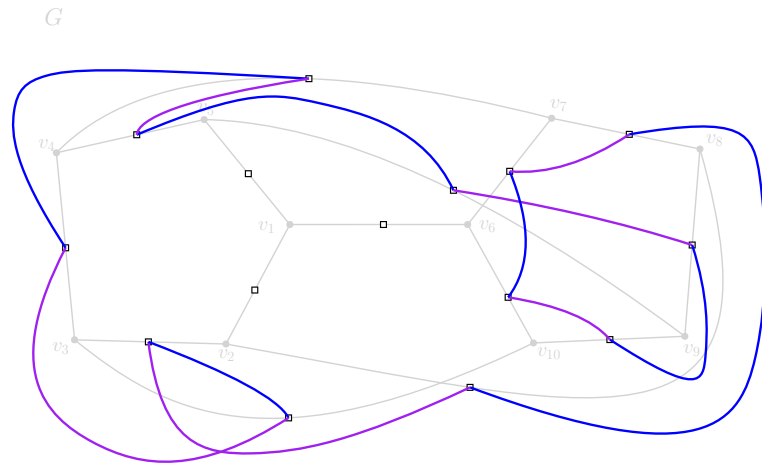

Figure 2.9: The matchings of $L(G)$ obtained from the orientations $H_{2,1}$ and $H_{2,2}$ of Proposition 11 in [4] in blue and purple, respectively.

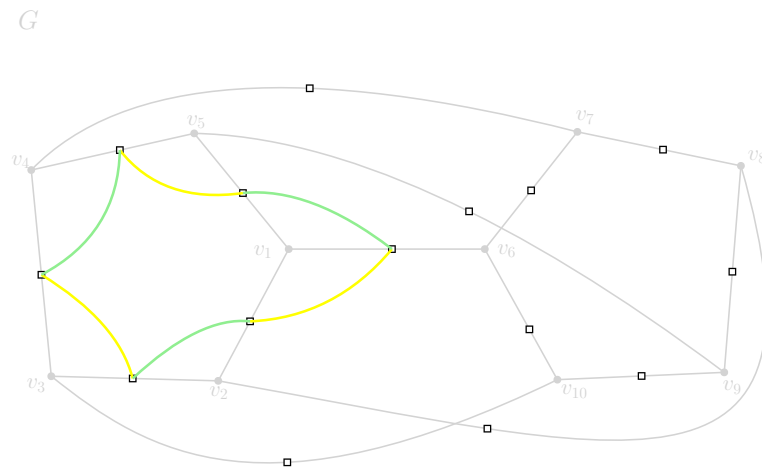

Figure 2.10: The matchings of $L(G)$ obtained from the orientations $H_{3,1}$ and $H_{3,2}$ of Proposition 11 in [4] in yellow and green, respectively.

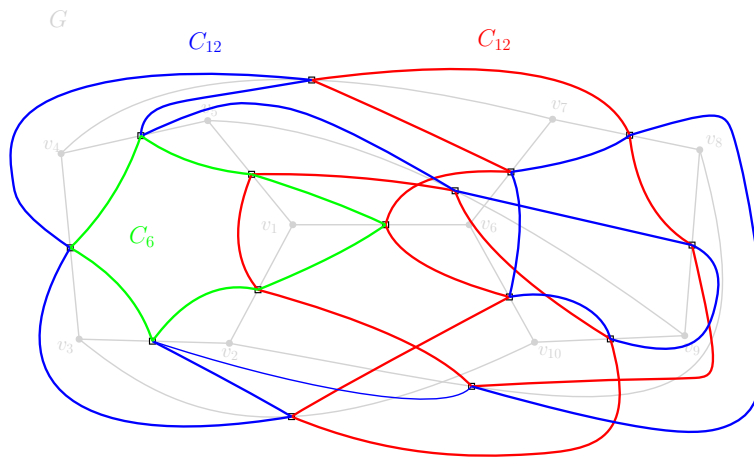

Figure 2.11: The even cycle decomposition of $L(G)$, where G is the Petersen graph, obtained from the Example 12 in [4]; the decomposition has index 3.

2.1. ON THE INDEX OF AN EVEN CYCLE DECOMPOSITION

Chapter 3

A novel coloring technique

We describe the technique introduced in [8] for coloring the edges of the line graph $L(G)$ of a cubic graph G . The technique can be used to modify the odd cycles of a 2-regular subgraph of $L(G)$ into odd paths. It is proved in [8] that if the starting odd cycles satisfy certain conditions, then the odd paths can be connected so as to form even cycles of the line graph. We deal with the conditions on the odd cycles in Chapter 4.

The following definitions are used in [8] for introducing the novel coloring technique and the main construction.

We define a $(1, 2)$ -subgraph F of an arbitrary graph G as a subgraph whose connected components are either paths or even cycles. If F contains no path, then F is a 2-regular subgraph of G . We say that F is an *even* $(1, 2)$ -subgraph of G if every component of F has even length; F will be an *even 2-regular subgraph* if it contains no path. A partition \mathcal{F} of the edge set of G into even $(1, 2)$ -subgraphs will be called an *even* $(1, 2)$ -decomposition of G . A $(1, 2)$ -subgraph of G will be considered as a colored class of a non-proper edge-coloring of G , an even $(1, 2)$ -decomposition \mathcal{F} consisting of $|\mathcal{F}|$ subgraphs will be referred to as an *even* $(1, 2)$ -decomposition of index $|\mathcal{F}|$. For \mathcal{F} consisting of even 2-regular subgraphs, we will speak of an *even cycle decomposition of index* $|\mathcal{F}|$.

We consider $(1, 2)$ -decompositions of the line graph of a class 1 graph G with maximum degree $\Delta(G) = 3$.

Given a class 1 graph G with $\Delta(G) = 3$, any proper 3-edge-coloring θ of G defines a non-proper 3-edge-coloring θ' of the corresponding line graph $L(G)$ whose colored classes form a $(1, 2)$ -decomposition of $L(G)$ of index 3. More precisely, let M_1, M_2, M_3 be the colored classes of θ . For every $1 \leq h < k \leq 3$, the union $M_h \cup M_k$ is a $(1, 2)$ -factor of G , since its connected components are either paths or even cycles. Consequently, $L(M_h \cup M_k)$ is a $(1, 2)$ -subgraph of $L(G)$.

We set $H_1 = L(M_1 \cup M_2)$, $H_2 = L(M_1 \cup M_3)$, $H_3 = L(M_2 \cup M_3)$ and color by red, green and blue the edges of H_1 , H_2 and H_3 , respectively. Since $\{H_1, H_2, H_3\}$ is a partition of the edge set of $L(G)$, a non-proper 3-edge-coloring θ' of $L(G)$, with color-set *red*, *green* and *blue*, is thus defined.

The following definition describes a novel coloring technique on the edges of $L(G)$ that modifies a blue path or cycle in H_3 into a pattern of red and green even paths, so that the number of odd paths in the red and green colored classes H_1 , H_2 does not increase.

For a class 2 cubic graph, we will use this technique to modify every blue odd cycle in the corresponding line graph into a pattern of red and green even paths together with exactly one blue odd path. We will connect the blue odd paths and form blue even cycles, so as to obtain an even cycle decomposition of $L(G)$ of index 3. In order to connect the blue odd paths, the coloring technique will be applied to the blue even cycles as well.

Definition 3.0.1. Let $P = (u_0, u_1, u_2, \dots, u_m, u_{m+1})$ be a path in $M_2 \cup M_3$ whose vertices u_i , $1 \leq i \leq m$, have degree 3; and u_0, u_{m+1} have degree 2. For $0 \leq i \leq m + 1$, we denote by e_i be the edge of M_1 which is incident to u_i , the edges e_i are not necessarily distinct.

Let $P_{2,i}$ and $P_{4,i}$ be the 2- and 4-path of $L(G)$ defined by $P_{2,i} = (v_{e_i}, v_{u_i u_{i+1}}, v_{e_{i+1}})$, where $0 \leq i \leq m$, $P_{4,i} = (v_{e_i}, v_{u_{i-1} u_i}, v_{u_i u_{i+1}}, v_{u_{i+1} u_{i+2}}, v_{e_{i+1}})$, where $1 \leq i \leq m - 1$.

For $u_0 u_1 \in M_2$, we modify the coloring θ' of $L(G)$ on the paths $P_{2,i}$ and

$P_{4,i}$ as follows:

- we color by blue the edges $v_{u_0u_1}v_{e_0}$, $v_{u_{m+1}u_m}v_{e_{m+1}}$;
- for $1 \leq i \leq m-1$, $i \equiv 1 \pmod{4}$, we color by green the 4-paths $P_{4,i}$;
- for $1 \leq i \leq m-1$, $i \equiv 3 \pmod{4}$, we color by red the 4-paths $P_{4,i}$;
- for $1 \leq i \leq m$, $i \equiv 1 \pmod{4}$, we color by red the 2-paths $P_{2,i}$; and leave unchanged the green color for $i \equiv 3 \pmod{4}$.

For $u_0u_1 \in M_3$, we swap be the red and green colors.

We apply the coloring technique of Definition 3.0.1 to the blue path in Figure 3.1(a), where the edge u_0u_1 of G belongs to the colored class M_2 . We obtain the pattern of red and green even paths of Figure 3.1(b) or (c) according to whether $m \equiv 2$ or $m \equiv 0 \pmod{4}$, respectively.

We denote by φ the new coloring of $L(G)$ obtained from Definition 3.0.1. Let H'_1 , H'_2 , H'_3 be the red, green and blue classes of φ that are obtained from the red, green and blue classes H_1 , H_2 , H_3 of θ , respectively. In the following lemma, we prove that the coloring technique of Definition 3.0.1 leaves invariant or decreases the number of odd paths in the red and green classes H'_1 , H'_2 .

The following lemma has been proved in [8].

Lemma 3.0.2. If the endvertices of every path in H_1 and H_2 correspond to edges of G belonging to the same colored class M_1 , then the red and green colored classes H'_1 , H'_2 of φ are even (1,2)-subgraphs of $L(G)$.

Moreover, v_{e_0} , $v_{e_{m+1}}$ are the endvertices of even paths in H'_1 and H'_2 , possibly the same path, or do not belong to $V(H'_1)$ and $V(H'_2)$ at all.

Proof. We uncolor the paths $P_{2,i}$, $1 \leq i \leq m$, in H_1 and H_2 so that the red and green components of H_1 and H_2 visiting the vertices v_{e_j} , $0 \leq j \leq m+1$, result in paths P' with at least one endvertex in $\{v_{e_j} : 0 \leq j \leq m+1\}$. Each red path P' has even length, possibly length 0. In fact, vertices corresponding

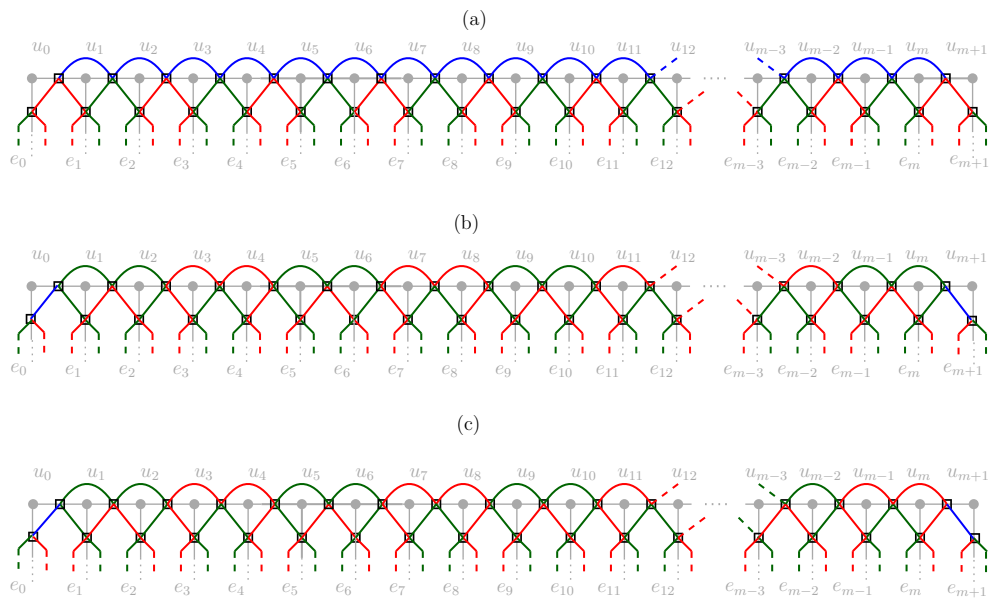

Figure 3.1: (a) The colored classes H_1, H_2, H_3 of the coloring θ' on the edges of $L(G)$ that are incident to the vertices in $L(P)$. In (b)-(c) we apply the coloring technique of Definition 3.0.1; (b) holds for $m \equiv 2 \pmod{4}$; (c) holds for $m \equiv 0 \pmod{4}$.

to edges in M_1 alternate to vertices corresponding to edges in M_2 , since $H_1 = L(M_1 \cup M_2)$; by the assumptions, the endvertices of P' correspond to edges in M_1 ; hence P' has even length. Analogously for the green paths P' .

The coloring φ connects the red paths P' by the even paths $P_{4,i}, P_{2,j}$, where $1 \leq i \leq m-1$, $i \equiv 3 \pmod{4}$, and $1 \leq j \leq m$, $j \equiv 1 \pmod{4}$, assuming that $u_0u_1 \in M_2$. Hence the resulting paths or cycles have even length, see for instance Figure 3.1(b)-(c). Analogously for the green paths P' . For $u_0u_1 \in M_3$, the red and green are swapped.

It is easy to see that $v_{e_0}, v_{e_{m+1}}$ are the endvertices of even paths in H'_1 and H'_2 , possibly the same path or of length 0. In this last case, $v_{e_0}, v_{e_{m+1}}$ do not belong to $V(H'_1)$ and $V(H'_2)$. ■

Example 3.0.3. Let G be the graph in Figure 3.2(a), the perfect matching M is represented by the dotted edges. We delete from G the edges $u_0u_6, u_3u_4, u'_0u'_6, u'_3u'_4$ and obtain the graph G' in Figure 3.2(b).

In Figure 3.2(a) we apply the coloring technique of Definition 3.0.1 to G' on the 3-paths (u_0, u_1, u_2, u_3) and (u'_0, u'_1, u'_2, u'_3) as in Fig.3.3(a). The blue colored class of the new 3-edge-coloring contains exactly two odd paths $P = (v_a, v_b)$ and $P' = (v_c, v_d)$ where $(a, b) = (u_4u_5, u_5u_6)$, $(c, d) = (u'_4u'_5, u'_5u'_6)$. In Figure 3.2(b), we connect P and P' by the blue 2-paths (v_a, v_b, v_c) where $(a, b, c) = (u_1u_0, u_0u_6, u_6u_5)$, $(u'_1u'_0, u'_0u'_6, u'_6u'_5)$.

We obtain an *ECD* of index 3 in $L(G)$ consisting of a blue 14-cycle; two green 4-cycles; and two red cycles of length 4 and 8.

We observe that the coloring technique can be applied to any perfect matching of G whose complementary 2-factor is given by the two 7-cycles $C = (u_0, u_1, u_2, u_3, u_4, u_5, u_6, u_0)$ and $C' = (u'_0, u'_1, u'_2, u'_3, u'_4, u'_5, u'_6, u'_0)$ provided that there are two edges $e, f \in E(G)$ with one vertex in C and the other in C' . This construction is a special case of the method introduced in [8] and will be described in detail in the next chapter.

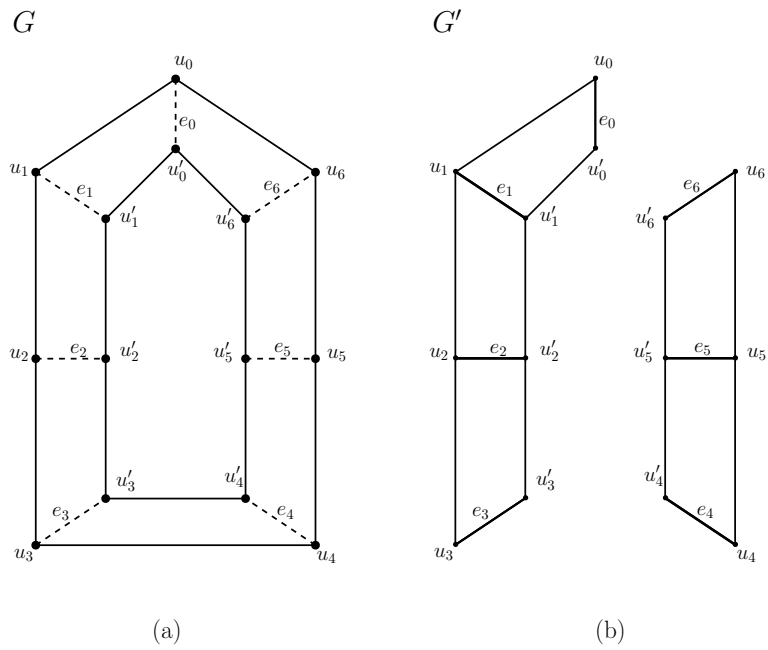

Figure 3.2: (a)-(b)The graphs G and G' in Example 3.0.3; G' is obtained from G by removing the edges $u_0u_6, u_3u_4, u'_0u'_6, u'_3u'_4$.

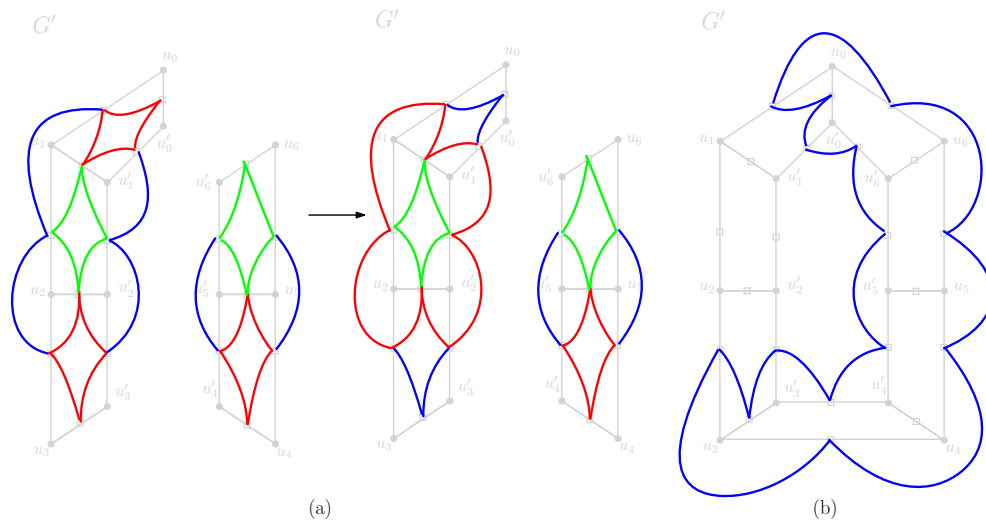

Figure 3.3: (a) An application of the coloring technique of Definition 3.0.1 to the 3-paths (u_0, u_1, u_2, u_3) and (u'_0, u'_1, u'_2, u'_3) in Example 3.0.3; in $L(G')$ we find the odd blue paths (v_a, v_b) where (a, b) is the pair of edges (u_4u_5, u_5u_6) and $(u'_4u'_5, u'_5u'_6)$; (b) The blue even cycle is obtained by connecting the blue odd paths in $L(G')$ by the blue 2-paths (v_a, v_b, v_c) where $(a, b, c) = (u_1u_0, u_0u_6, u_6u_5), (u'_1u'_0, u'_0u'_6, u'_6u'_5)$.

Chapter 4

The main construction

In this chapter, G is a bridgeless cubic graph, M and $G - M$ will denote a perfect matching of G and its complementary 2-factor, respectively.

We define the *cycle-multigraph of G relative to M* , denoted by $\mathcal{C}(G, M)$, as the multigraph obtained from G by contracting each cycle of $G - M$ into a vertex and removing the resulting loops. By construction, the edges of $\mathcal{C}(G, M)$ correspond to the edges of M . A vertex of $\mathcal{C}(G, M)$ corresponding to the cycle C of $G - M$ will be denoted by v_C . Vertices of $\mathcal{C}(G, M)$ corresponding to cycles of odd length will be called *odd cycle-vertices*; vertices corresponding to cycles of even length will be called *even cycle-vertices*. Since G is connected, the graph $\mathcal{C}(G, M)$ is also connected and contains an even number of odd cycle-vertices.

We describe the method introduced in [8] for the construction of an even cycle decomposition of index 3 in the line graph of a bridgeless cubic graph of oddness 2 and in the line graph of cubic graphs of oddness larger than 2 belonging to known infinite families. For these last graphs it is possible to find a cycle-multigraph $\mathcal{C}(G, M)$ containing a subgraph spanning the odd cycle-vertices and whose connected components are cycles having an even number of odd cycle-vertices. We will use the following lemmata.

Lemma 4.0.1. Every cycle of $\mathcal{C}(G, M)$ containing an even number of odd cycle-vertices has a 2-edge coloring, say by red and green, such that its odd

cycle-vertices are incident to edges of distinct colors; even cycle-vertices are incident to edges of the same color.

Proof. Since the number of odd cycle-vertices is even, we can color the edges that are incident to them by distinct colors; and the edges that are incident to the even cycle-vertices by the same color. ■

We adopt the following notation.

Notation 4.0.2. For a cycle-vertex v_C in $\mathcal{C}(G, M)$ having degree $d \geq 2$, we label two incident edges by f, g . Then M contains at least two edges, say uu', vv' , providing the edges f, g while contracting the cycles of $G - M$, where $u, v \in V(C), u', v' \notin V(C)$.

The cycle C can be represented as the vertex-disjoint union of the paths $u P^C v = (u, u_1, \dots, u_m, v), w_1 P^C w_n = (w_1, \dots, w_n)$ together with the edges uw_1, vw_n . For an odd cycle C , the path $u P^C v$ will denote the subpath of odd length.

The edges M that are incident to u, v will be labeled by f, g as in $\mathcal{C}(G, M)$, respectively.

By Notation 4.0.2, we define the auxiliary graph G' as follows.

Definition 4.0.3. Let C be an odd cycle of $G - M$ whose corresponding odd cycle-vertex v_C has degree $d \geq 2$ in $\mathcal{C}(G, M)$. According to Notation 4.0.2, the cycle C is the vertex-disjoint union of the paths $u P^C v = (u, u_1, \dots, u_m, v), w_1 P^C w_n = (w_1, \dots, w_n)$ together with the edges uw_1, vw_n .

We define G' as the graph obtained from G by deleting the edges uw_1, vw_n in every odd cycle C of $G - M$.

It is easy to see that G' is class 1, since in every odd cycle C of $G - M$ at least one edge has been removed. Moreover, its maximum degree is $\Delta(G') \leq 3$. The graphs G' and $L(G')$ inherit the edge-coloring of G and $L(G)$ defined by M . More specifically, the following lemma holds.

Lemma 4.0.4. The perfect matching M induces a proper 3-edge-coloring θ of G' with color-set $\{a_1, a_2, a_3\}$, where the edges of M are colored by a_1 , that ones of $G' - M$ are colored alternately by a_2, a_3 in such a way that $\theta(uu_1) = \theta(vu_m) = \theta(w_1w_2) = a_3$ and $\theta(w_{n-1}w_n) = a_2$, for every odd cycle C of $G - M$ whose vertices are labeled according to Notation 4.0.2. Consequently, the palettes of the vertices are contained in $\{\{a_1\}, \{a_1, a_2\}, \{a_1, a_3\}, \{a_1, a_2, a_3\}\}$.

For $i = 1, 2, 3$, let M_i be the colored class of θ consisting of the edges of color a_i . Then θ defines a non-proper 3-edge-coloring θ' of $L(G')$ whose colored classes $H_1 = L(M_1 \cup M_2)$, $H_2 = L(M_1 \cup M_3)$ are even $(1, 2)$ -subgraphs of $L(G')$. The endvertices of the paths in H_1 correspond to the edges of $M = M_1$ that are incident to the vertices u, v, w_1 of every odd cycle C of $G - M$; the endvertices of the paths in H_2 correspond to the edges of $M = M_1$ that are incident to the vertex w_n of every odd cycle C of $G - M$.

Proof.

Since G' is obtained from G by deleting the edges uw_1, vw_n in every odd cycle C of $G - M$ which is colored alternately by a_2, a_3 , no vertex of G' has palette $\{a_2, a_3\}$. Notice that we can color alternately the edges of G' in such a way that $\theta(uu_1) = \theta(vu_m) = \theta(w_1w_2) = a_3$ and $\theta(w_{n-1}w_n) = a_2$, since uP^Cv has odd length and $w_1P^Cw_n$ has even length, see Notation 4.0.2. Hence, the palettes of the vertices are contained in $\{\{a_1\}, \{a_1, a_2\}, \{a_1, a_3\}, \{a_1, a_2, a_3\}\}$.

By the remarks in Chapter 3, the colored classes H_1, H_2, H_3 are $(1, 2)$ -subgraphs of $L(G')$. Since the palettes of the vertices of G' are contained in $\{\{a_1\}, \{a_1, a_2\}, \{a_1, a_3\}, \{a_1, a_2, a_3\}\}$, the paths in $M_1 \cup M_2$ and in $M_1 \cup M_3$ start and end with edges of M_1 , that is, they have odd length. Consequently, the paths in H_1, H_2 have even length and the endvertices correspond to edges of $M = M_1$. More specifically, the endvertices of the paths in H_1 correspond to the edges of $M = M_1$ that are incident to the vertices u, v, w_1 of every odd cycle C of $G - M$, since $\theta(uu_1) = \theta(vu_m) = \theta(w_1w_2) = a_3$. The endvertices of the paths in H_2 correspond to the edges of $M = M_1$ that are incident to the vertex w_n of every odd cycle C of $G - M$, since $\theta(w_{n-1}w_n) = a_2$.

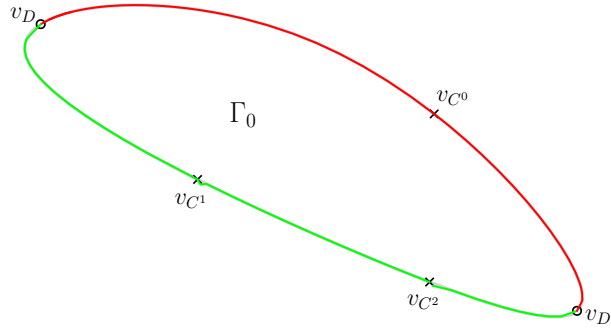

Figure 4.1: The cycle Γ of Example 4.0.6 endowed with the 2-coloring, by red and green, of Lemma 4.0.1.

Notice that the vertices of G' with palette $\{a_1\}$, if any, provide isolated vertices, or equivalently paths of null length, that will be not considered in H_1, H_2 . ■

Remark 4.0.5. The whole set of edges of $M = M_1$ that are incident to the vertices u, v, w_1, w_n of the odd cycles C of $G - M$ are not necessarily distinct. Hence, an endvertex of a path in H_1 might be also an endvertex of a path in H_2 .

We give an example showing the role of the auxiliary graphs $G', L(G')$ and the process that led to obtain the even cycle decomposition of index 3 in $L(G)$ by the sets of cycles satisfying the Lemma 4.0.1.

Example 4.0.6. Assume that $\mathcal{C}(G, M)$ has exactly two odd cycle-vertices and contains a cycle Γ visting them. The edges of Γ can be colored by red and green in accordance with Lemma 4.0.1, see Figure 4.1. For the sake of brevity, we assume that the odd cycles D, D' and the even cycles C are the 5- and 6-cycles in Figure 4.2.

We replace each cycle-vertex v_C by the corresponding cycle C in such a way that the edges of Γ that are incident to v_C correspond to the edges of G with the same label. For $C = D, D'$, we also remove the edges uw_1 ,

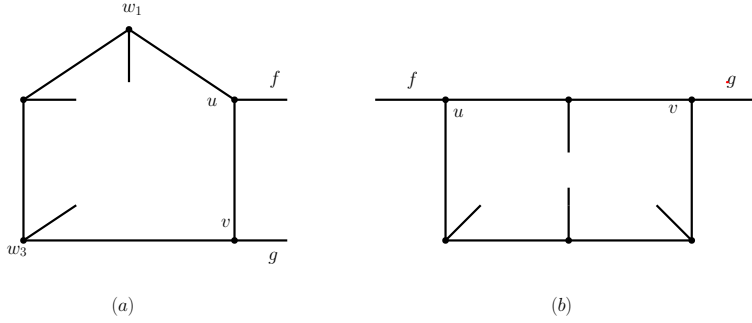

Figure 4.2: The cycles corresponding to the cycle-vertices of Example 4.0.6: (a) holds for the odd cycle-vertices $v_D, v_{D'}$; (b) holds for the even cycle-vertices of degree 2 in Γ .

$vw_n = vw_3$ and obtain the graph G' defined in Definition 4.0.3. We construct the line graph $L(G')$ endowed with the coloring θ' of Lemma 4.0.4 by replacing the cycle-vertices v_C with the graphs in Figure 4.3. Notice that a vertex v_e of $L(G')$, corresponding to the edge $e \in M = M_1$, is incident to two red edges and two green edges, provided that the endvertices of e are different from the vertices u, v, w_1, w_3 of the odd cycles D, D' of $G - M$. By Lemma 4.0.4 and Remark 4.0.5, if the edge $e \in M = M_1$ is incident to u, v, w_1 (respectively, w_3) then v_e is incident to λ green edges and μ red edges, where $1 \leq \lambda \leq 2$ and $0 \leq \mu \leq 1$ (respectively, $0 \leq \lambda \leq 1$ and $1 \leq \mu \leq 2$).

We apply Definition 3.0.1 and obtain the 3-edge-coloring φ of $L(G)$ by modifying the colored classes H_1, H_2, H_3 of θ' as follows. We consider the cycles C of $G - M$ with corresponding cycle-vertex v_C in Γ ; the edges of $L(G')$ that are incident to the vertices in $L(C)$ are colored according to the edge-coloring θ' of Lemma 4.0.4.

For an odd cycle $C = D, D'$, we delete uv and apply Definition 3.0.1 to the path $uw_1 \cup w_1 P^C w_3$, we obtain a colored subgraph of $L(G' \cup uw_1)$ that we complete to the colored subgraph of $L(G)$ in Figure 4.4(a). Analogously, for the even cycles C with v_C in Γ we delete a suitable set S of edges and apply Definition 3.0.1 to the resulting paths; we obtain a colored subgraph of $L(G - S)$ that we complete to the colored subgraph of $L(G)$ in Figure 4.4(b).

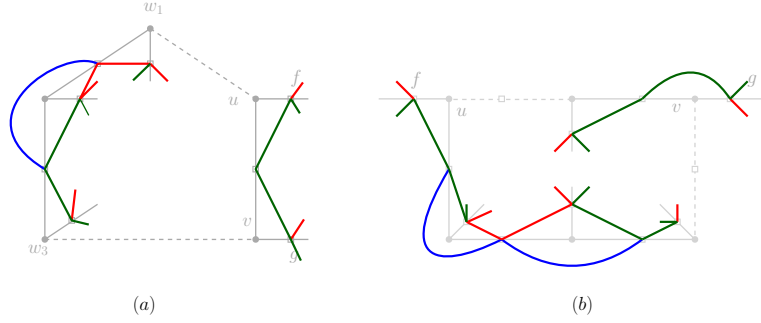

Figure 4.3: The line graph $L(G')$ of Example 4.0.6 endowed with the coloring θ' defined in Lemma 4.0.4 is obtained by replacing the cycle-vertices v_C in Γ by the graphs in the figure: (a) holds for $C = D, D'$ where uw_1, vw_3 have been removed; (b) holds for the even cycles C with v_C of degree 2 in Γ .

In Figure 4.5 we represent $L(G)$ endowed with φ . The underlying cycles of the colored graphs in Figure 4.4(a)-(b) will be called ‘fitting cycles’, as they have just one blue path - odd in case (a) and even in case (b) - connecting to the left and right blue parts.

As remarked, the blue colored class is an even 2-regular subgraph of $L(G)$, since it contains no odd cycle. The same holds for the red and green colored classes: it follows from the properties of the graphs in Figure 4.4 and from Lemma 3.0.2, as the colored classes of φ have been obtained from the colored classes of θ' by applying Definition 3.0.1.

We formalize the definition of fitting cycles and prove the main construction in 4.0.8.

Lemma 4.0.7. Fitting cycles. Let C be a cycle of $G - M$ whose corresponding cycle-vertex v_C belongs to $V(\Gamma)$, and Γ is the cycle of $\mathcal{C}(G, M)$ satisfying the Lemma 4.0.1; v_C has degree 2 in Γ ; vertices and edges of C are labeled according to Notation 4.0.2. We modify the edge-coloring θ' on the edges of $L(G')$ that are incident to the vertices in $L(C)$ by applying Definition 3.0.1. We obtain a coloring of $L(G)$ satisfying the following properties:

- (1) $L(C \cup \{f, g\})$ contains a blue path with endvertices v_f, v_g having even or

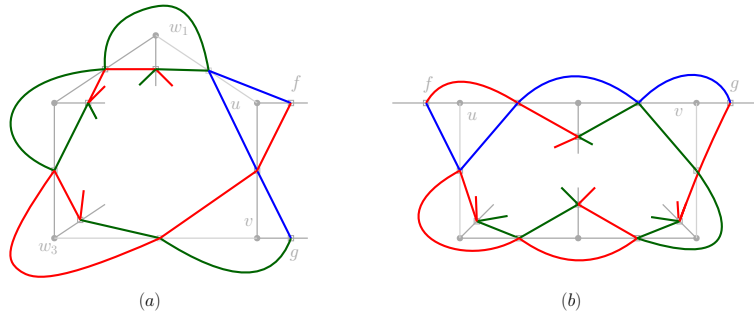

Figure 4.4: The colored subgraphs of $L(G)$ in Example 4.0.6 obtained by applying Definition 3.0.1 to the cycles C of $G - M$ with v_C in Γ : (a) holds for the odd cycles D, D' if the edges f, g incident to $v_D, v_{D'}$ in Γ are red and green, respectively; we swap the colors red and green if f is green and g is red in Γ . (b) holds for the even cycles C with v_C of degree 2 in Γ whose incident edges f, g are colored by red, we swap the colors red and green if f, g are green.

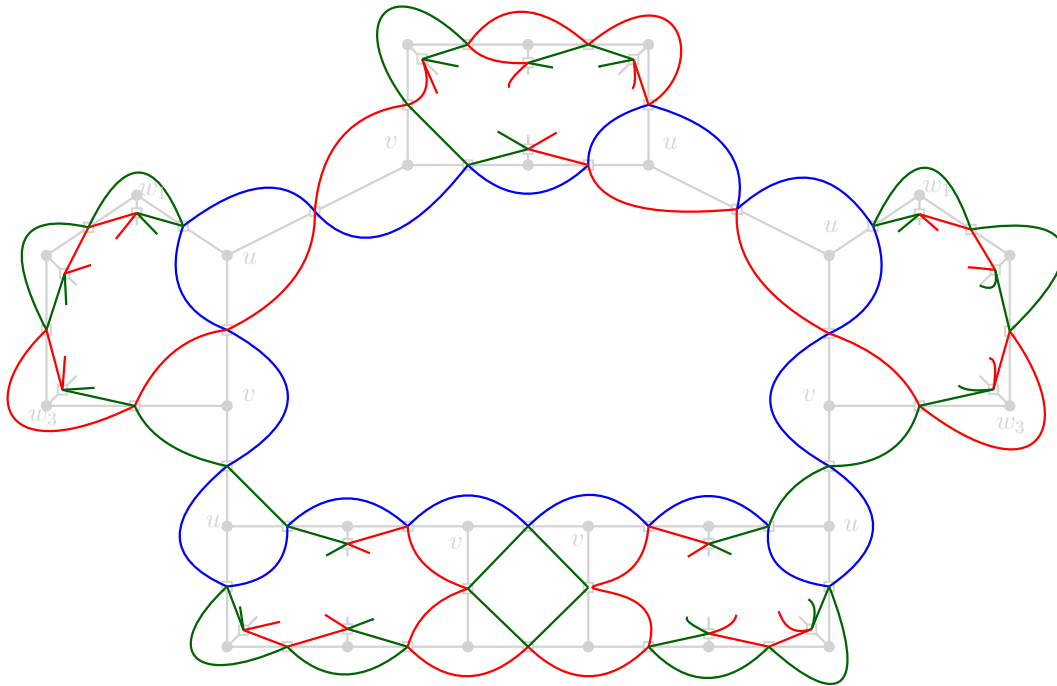

Figure 4.5: The graph $L(G)$ in Example 4.0.6 endowed with the coloring φ .

odd length according to whether C has even or odd length, respectively;

- (2) if the edge $e \in \{f, g\}$ is colored by red (respectively, green) in Γ , then there is a red (respectively, green) even path with vertices in $L(C \cup M_C)$ connecting v_e to a vertex $v_{e'}$ where $e' \in M_C$, $e \neq e'$.

The cycle C will be called a *fitting cycle*.

Proof. We modify the coloring θ' on the edges of $L(G')$ that are incident to the vertices in $L(C)$ by applying Definition 3.0.1 to a suitable odd path of C , which is obtained by removing a prescribed set of edges of C . For an odd path of length larger than 1, Definition 3.0.1 provides a pattern of red and green even paths together with two blue edges, see for instance Figure 3.1; for an odd path of length 1, it provides just two blue incident edges.

As for the edges of $M = M_1$ that are incident to the vertices u_1, u_m, w_1, w_n of C , we will use the notation e_1, e_m, h_1, h_n , respectively.

We distinguish the following cases: v_C is an odd cycle-vertex; v_C is an even cycle-vertex.

Case 1: v_C is an odd cycle-vertex.

According to Notation 4.0.2, that path $u P^C v$ is the subpath of C having odd length; we recall that in G' the edges $uw_1, vw_n \in E(C)$ have been removed. By the Lemma 4.0.1, the edges f, g have distinct colors in Γ , say red and green, respectively. We modify the coloring θ' as follows.

If $\ell(u P^C v) > 1$, then we apply Definition 3.0.1 to the path $u P^C v$ so that the following edges of $L(G)$ become blue: $v_a v_b$ with $(a, b) = (f, uu_1), (g, vv_m)$. We add the blue 2-paths (v_a, v_b, v_c) , where $(a, b, c) = (w_1 w_2, uw_1, uu_1), (w_{n-1} w_n, vw_n, vv_m)$, and obtain an odd blue path with endvertices v_f, v_g . We also add the red 2-path (v_a, v_b, v_c) where $(a, b, c) = (h_1, uw_1, f)$ and the green 2-path (v_a, v_b, v_c) where $(a, b, c) = (h_n, vw_n, g)$, that connect to the red (respectively, green) even paths in $L(G')$ with endvertices corresponding to the edges of $M = M_1$ that are incident to u, v, w_1 (respectively, to w_n), see Lemma 4.0.4. The resulting coloring of $L(G)$ satisfies the properties (1)-(2), that is, the cycle C is fitting. See for instance the 7-cycle in Figure 4.6(b).

If $u P^C v = (u, v)$, then in G' we delete the edge uv and add the edge uw_1 ; and apply Definition 3.0.1 to the path $uw_1 \cup w_1 P^C w_n$. The following edges of $L(G)$ become blue: $v_a v_b$ with $(a, b) = (f, uw_1), (w_{n-1}w_n, h_n)$. We recolor the edge $v_{w_{n-1}w_n} v_{h_n}$ by adding the red 4-path $(v_a, v_b, v_c, v_d, v_e)$ where $(a, b, c, d, e) = (h_n, w_{n-1}w_n, vw_n, uv, f)$; and the green 2-path (v_a, v_b, v_c) where $(a, b, c) = (h_n, vw_n, g)$. We also add the blue 2-path (v_{uw_1}, v_{uv}, v_g) that combined with the blue edge $v_f v_{uw_1}$ form an odd blue path. The resulting coloring of $L(G)$ satisfies the properties (1)-(2), that is, C is a fitting cycle. See for instance the 5-cycle in Figure 4.4(a) of Example 4.0.6 or the 3-cycle in Figure 4.6(a).

Case 2: v_C is an even cycle-vertex.

By the Lemma 4.0.1, the edges f, g have the same color in Γ , say red.

If $u P^C v = (u, v)$, then we delete the edge uv and apply Definition 3.0.1 to the path $uw_1 \cup w_1 P^C w_n \cup vw_n$ so that the edges $v_f v_{uw_1}, v_g v_{vw_n}$ of $L(G)$ become blue. We add the red 2-path (v_f, v_{uv}, v_g) ; and the blue 2-path $(v_{uw_1}, v_{uv}, v_{vw_n})$. The resulting coloring of $L(G)$ satisfies the properties (1)-(2), that is, the cycle C is fitting. See for instance the 4-cycle in Figure 4.7(a).

If $u P^C v$ has odd length $\ell > 1$, then we delete the edges uu_1, vu_m and apply Definition 3.0.1 to the path $uw_1 \cup w_1 P^C w_n \cup vw_n$ so that the edges $v_f v_{uw_1}, v_g v_{vw_n}$ of $L(G)$ become blue. We add the blue 2-paths (v_a, v_b, v_c) where $(a, b, c) = (uw_1, uu_1, u_1 u_2), (vw_n, vu_m, u_{m-1} u_m)$ that, combined with the blue edges $v_f v_{uw_1}, v_g v_{vw_n}$ and the blue even path $L((u_1, \dots, u_m))$ form an even blue path with endvertices v_f, v_g . We also add the red 2-paths (v_a, v_b, v_c) where $(a, b, c) = (f, uu_1, e_1), (g, vu_m, e_m)$. The resulting coloring of $L(G)$ satisfies the properties (1)-(2), that is, the cycle C is fitting. See for instance the 8-cycle in Figure 4.7(c).

As for $u P^C v$ of even length $\ell \geq 2$, we delete the edges uu_1, vw_n and apply Definition 3.0.1 to the path $uw_1 \cup w_1 P^C w_n$. The following edges of $L(G)$ become blue: $v_a v_b$ with $(a, b) = (f, uw_1), (h_n, w_{n-1}w_n)$. We recolor the edge $v_{h_n} v_{w_{n-1}w_n}$ by adding the green 4-path $(v_{h_n}, v_{w_{n-1}w_n}, v_{vw_n}, v_{vu_m}, v_{e_m})$;

and the red 2-paths (v_a, v_b, v_c) where $(a, b, c) = (f, uu_1, e_1), (g, vw_n, h_n)$. We also add the blue edge $v_g v_{uu_m}$ and the blue 2-path $(v_{uw_1}, v_{uu_1}, v_{u_1 u_2})$ that combined with the odd blue path $L((u_1, \dots, u_m, v))$ form an even blue path with endvertices v_f, v_g . The resulting coloring of $L(G)$ satisfies the properties (1)-(2), that is, the cycle C is fitting. See for instance the 8-cycle in Figure 4.4(b) or the 4- and 6-cycles in Figure 4.7(b) and (d). ■

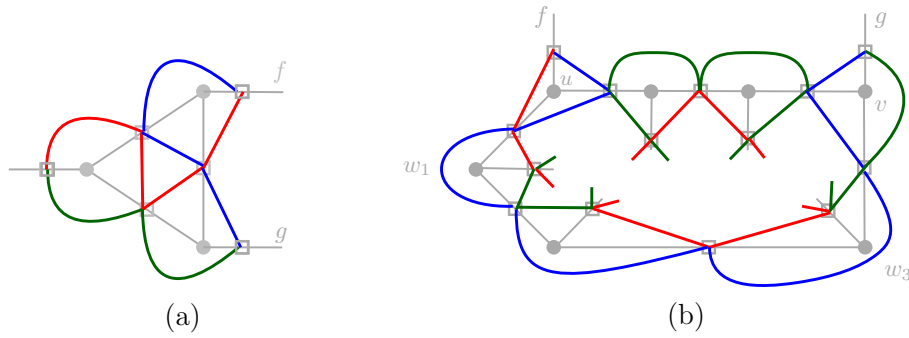

Figure 4.6: An odd cycle C in Lemma 4.0.7.

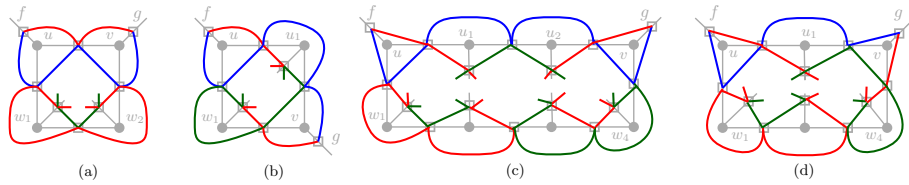

Figure 4.7: An even cycle C in Lemma 4.0.7

Theorem 4.0.8. (The main construction) Let G be a bridgeless cubic graph having a perfect matching M whose cycle-multigraph $C(G, M)$ has a subgraph spanning the odd cycle-vertices and whose connected components are cycles containing an even number of odd cycle-vertices. Then $L(G)$ has an even cycle decomposition of index 3.

Proof. The proof is a generalization of Example 4.0.6. Let G' be the class 1 graph of Definition 4.0.3. Let Γ be a cycle in $C(G, M)$ spanning an even

number of odd cycle-vertices and satisfying the Lemma 4.0.1. We consider the line graph $L(G')$ endowed with the coloring θ' defined in Lemma 4.0.4. As in Example 4.0.6, we firstly modify the coloring θ' on the edges of $L(G')$ that are incident to the vertices in $L(C)$, where C is a cycle of $G - M$ with v_C in Γ . Secondly, we complete the new coloring of $L(G')$ to a coloring φ of $L(G)$. More specifically, in Γ we replace every cycle-vertex v_C of degree 2 by the corresponding fitting cycle. The coloring φ colors the edges of $L(G)$ that are incident to the vertices in $L(C)$ according to Lemma 4.0.7.

By Lemma 4.0.7, the red, green and blue colored classes H'_1, H'_2, H'_3 of φ are obtained from the red, green and blue colored classes H_1, H_2, H_3 of θ' , respectively. By construction, every vertex of $L(G)$ is incident to exactly two edges of the same color. Hence, every colored class of φ is a 2-regular subgraph of $L(G)$. We show that they are even 2-regular subgraphs.

The colored classes H'_1, H'_2 are obtained from H_1, H_2 by firstly applying Definition 3.0.1 and secondly by adding red and green even paths with endvertices $v_e, v_{e'}$, where $e \in \{f, g\}$ $e' \in M_C, e \neq e'$. By applying Definition 3.0.1 to H_1 and H_2 , the red and green edges still form two even $(1, 2)$ -subgraphs of $L(G)$, since Lemma 3.0.2 and 4.0.4 hold. By adding the red and green even paths with endvertices $v_e, v_{e'}$, the red and green edges form two even 2-regular subgraphs H'_1, H'_2 of $L(G)$.

As for the blue colored class H'_3 , a cycle C of $G - M$ with v_C not belonging to Γ provides exactly one blue even cycle of H'_3 as its edges are colored alternately by a_2, a_3 (see Lemma 4.0.4).

We consider those cycles C with corresponding cycle-vertex v_C in Γ . By Lemma 4.0.7, a fitting cycle C contributes with exactly one blue path in forming a blue cycle of H'_3 ; the blue path has even or odd length according to whether C has even or odd length, respectively.

Consequently, Γ provides exactly one blue even cycle, since it spans an even number of odd cycle-vertices.

It is thus proved that the blue colored class H'_3 is an even 2-regular subgraph of $L(G)$. The assertion follows. ■

As proved in [8], Theorem 4.0.8 holds for the line graphs of the smallest snarks having oddness 4.

Proposition 4.0.9. The line graphs of the smallest snarks of oddness 4 - see Figure 4.8 - have an even cycle decomposition of index 3.

Proof. For each graph G in Figure 4.8, the bold edges define a perfect matching M whose complementary 2-factor has exactly four odd cycles. The cycle-multigraph $\mathcal{C}(G, M)$ of the graphs in Figure 4.8(a)-(b) has a cycle consisting of the four odd cycle-vertices. The cycle-multigraph of the graph G in Figure 4.8(c) admits a partition of the odd cycle-vertices into two dipoles, each consisting of two edges and two odd cycle-vertices. The assertion follows from Lemma 4.0.1 and Theorem 4.0.8. ■

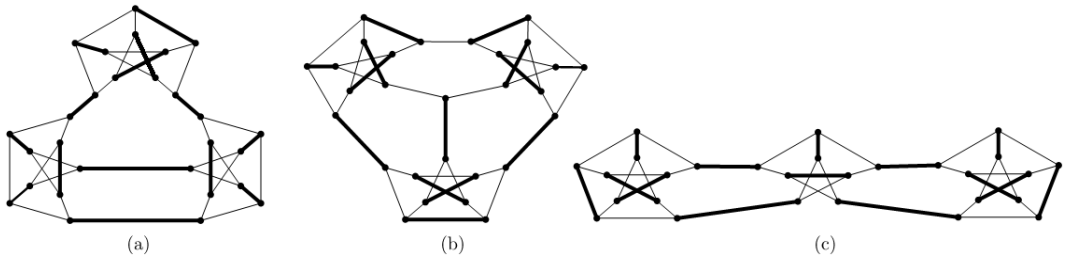

Figure 4.8: The smallest snarks of oddness 4 [22].

Chapter 5

Cubic graphs of arbitrary large oddness

We apply Theorem 4.0.8 to cubic graphs of oddness larger than 2 belonging to known infinite families constructed in [12], [22] and obtain an *ECD* of index 3 in the corresponding line graph.

The perfect matching M , that will be used to prove the existence of an even cycle decomposition of index 3 in the corresponding line graph, does not necessarily provide the oddness of the snark.

The snarks in [12] are obtained by the *semi blowup* and *blowup* of a pair (G, H) , where G is a bridgeless cubic graph and H is a 2-regular subgraph of G . Both operations use the base block B , which is obtained from the Petersen graph by removing a pair of adjacent vertices.

The semi blowup and blowup of (G, H) are described by Figure 5.1: for every k -cycle $C = (v_1, \dots, v_k)$ of H , the construction considers k copies of B , remove each edge $v_i v_{i+1}$ of C and connect v_i to the i -th and $(i + 1)$ -th copy of B .

Proposition 5.0.1. Let G be a bridgeless cubic graph and let M be a perfect matching of G . Let H be a 2-regular subgraph of the complementary 2-factor $G - M$ containing no odd cycle and such that in the cycle-multigraph $\mathcal{C}(G, M)$ the odd cycle-vertices corresponding to the odd cycles of $G - M$, if any, can

be partitioned into sets of cycles satisfying the Lemma 4.0.1.

Then the line graph of the semiblowup and blowup of (G, H) has an even cycle decomposition of index 3.

Proof. The bold edges in Figure 5.1(a) and (b) together with the edges of M form a perfect matching M^* of the semi blowup and blowup of (G, H) , respectively. The complementary 2-factor of M^* contains the odd cycles of $G - M$, if any.

For every k -cycle C of H , it also contains k cycles of length 9 for the semi blowup of (G, H) ; and k cycles of length 11 for the blow up of (G, H) . In the cycle-multigraph relative to M^* the odd cycle-vertices corresponding to the odd cycles coming from the same k -cycle C of H form a k -cycle. As k is even, the Lemma 4.0.1 is satisfied. Since the same property is satisfied for the odd cycle-vertices corresponding to the odd cycles not belonging to H , the assertion follows from Theorem 4.0.8. ■

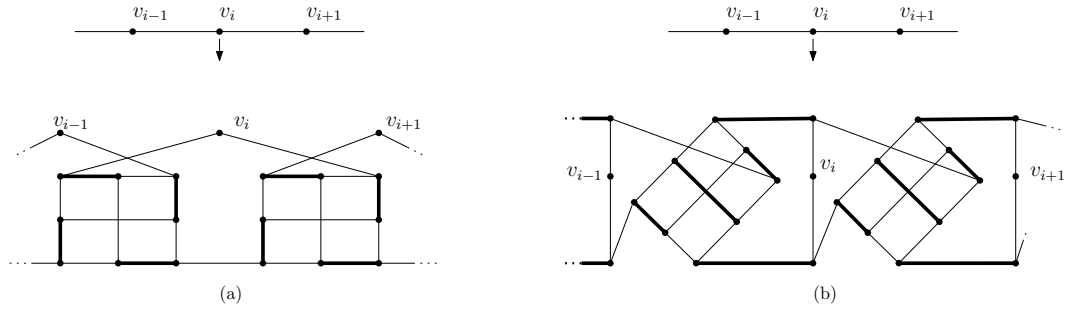

Figure 5.1: (a)-(b) The semi blowup and blowup of (G, H) , respectively.

We consider the snarks with cyclic connectivity 4 and 5 that are constructed in [22]. These graphs are obtained from the base blocks P_4^v , P_4^e , P_5^{vvv} , P_5^{ev} in Figure 5.2. The edges that are incident to 1-valent vertices will be called *terminal edges* and are partitioned into pairs as described in [22]. The basic operation is the join of terminal edges: two terminal edges are joined if the corresponding 1-valent vertices are identified so as to form a 2-valent vertex that will be suppressed.

The join of the terminal edges in P_4^v and P_4^e defines the graphs N_1, N_2 that are used to construct the snarks with cyclic connectivity 4; the join of the terminal edges in P_5^{vvv} and P_5^{ev} defines the graph Z that will be used to construct the snarks with cyclic connectivity 5.

More specifically, the graph N_1 is obtained from the join of a pair of terminal edges from P_4^v with a pair of terminal edges from P_4^e . The graph N_2 is obtained from two copies of P_4^v and one copy of P_4^e ; each pair of terminal edges from P_4^e is joined to a pair of terminal edges in a different copy of P_4^v . For the construction of a snark with cyclic connectivity 4, in [22] the authors arrange into a circuit an arbitrary number of copies of N_1 and N_2 ; and join one pair of terminal edges from each copy to a pair of terminal edges of succeeding copy, so as the pairs of the first and last copy are joined. As remarked in [22], several non-isomorphic graphs can be obtained from the same number of copies of N_1, N_2 .

The graph Z is obtained from two copies of P_5^{ev} and one copy of P_5^{vvv} ; each pair of terminal edges from P_5^{vvv} is joined to a pair of terminal edges in a different copy of P_5^{ev} , so as the terminal edges of Z can be partitioned into two triples and one singleton. A snark with cyclic connectivity 5 is obtained by joining the terminal edges from r, r even, disjoint copies of Z so as to form a graph with cyclic connectivity 5.

For the line graph of a snark constructed as described above, the following result holds.

Proposition 5.0.2. Let G be a snark with cyclic connectivity 4 or 5 as constructed in [22]. Then $L(G)$ has an even cycle decomposition of index 3.

Proof. By construction of G , the bold edges of the base blocks in Figure 5.2 define a perfect matching M of G .

In the case of cyclic connectivity 4, the complementary 2-factor $G - M$ contains exactly one 8-cycle from each copy of P_4^v ; and exactly two 5-cycles from each copy of P_4^e . In the cycle-multigraph $\mathcal{C}(G, M)$, each pair of odd cycle-vertices corresponding to the odd cycles of $G - M$ coming from the same copy of P_4^v forms a dipole with two vertices and two edges. Hence,

$\mathcal{C}(G, M)$ admits a partition of the odd cycle-vertices into dipoles. Since each dipole is a cycle satisfying the Lemma 4.0.1, the existence of an even cycle decomposition of index 3 in $L(G)$ follows from Theorem 4.0.8.

In the case of cyclic connectivity 5, the complementary 2-factor $G - M$ contains exactly one 25-cycle from each copy of Z . In the cycle-multigraph $\mathcal{C}(G, M)$, the odd cycle-vertices form a cycle. Hence, the Lemma 4.0.1 is satisfied and the assertion follows from Theorem 4.0.8. ■

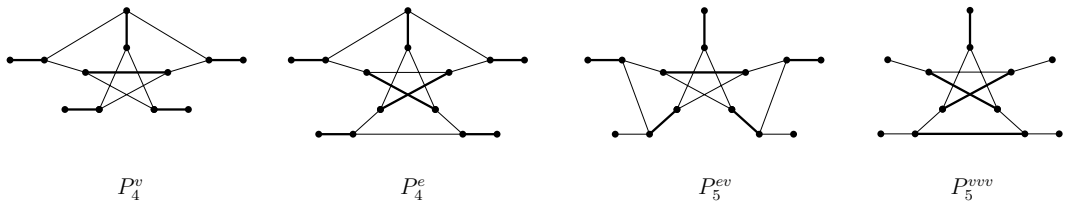

Figure 5.2: The base blocks of the construction in [22].

We apply our construction to the infinite class of cyclically 6-connected class 2 cubic graphs of arbitrary large oddness that are constructed in [22]. These graphs are obtained from the base block P_3 in Figure 5.3 (a). The join of r copies of P_3 , where $r \geq 2$, defines the cubic graph L_3 . More specifically we arrange r copies of P_3 into a circuit and join one terminal edge from each copy to a terminal edge of its successor, so as the terminal edges of the first and last copy are joined as in Figure 5.3 (b). This leaves one terminal of each copy unmatched and produces an r -pole. We partition the terminals of this r -pole into pairs and, if r is odd, one triple. We replace the endvertices of the bold edges in Figure 5.3(a) by the supervertex X in Figure 5.4(a); and the same bold edges by the superedge Y in Figure 5.4(b). We refer to [20] for the definition of the supervertex X and the superedge Y . The superedge Y is created from the flower snark J_5 by splitting off two non-adjacent vertices, one from the single 5-cycle of J_5 ; we call this block Q , see Figure 5.5 where the squares represent the superedges Y .

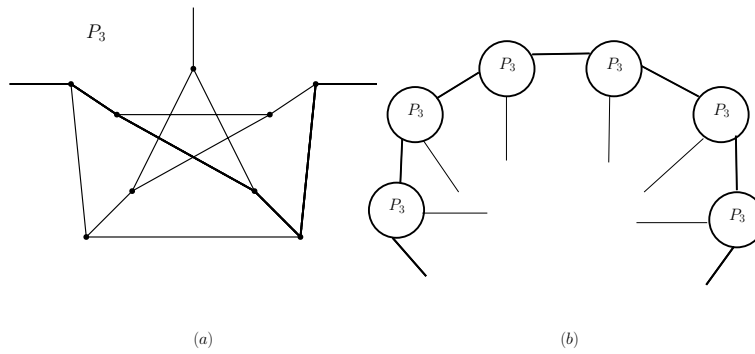

Figure 5.3: (a) The base block P_3 of the construction in [22]; (b) the arrangement of the copies of P_3 .

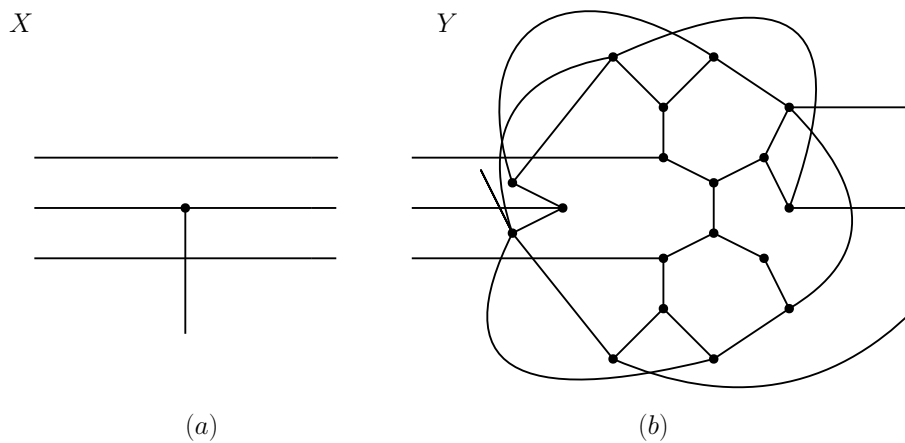

Figure 5.4: (a) The supervertex X ; (b) the superedge Y .

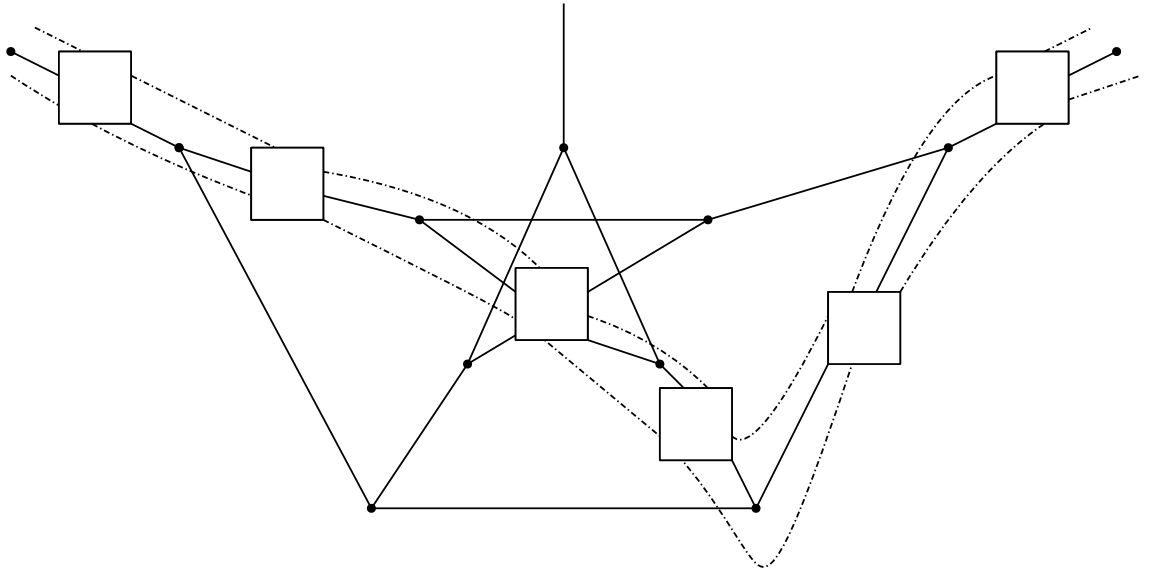

Figure 5.5: The block Q constructed from a copy of P_3 by the supervertices X and the superedges Y .

Proposition 5.0.3. Let G be a class 2 cubic graph as constructed in [22] having arbitrary large oddness and cyclic connectivity 6. Then $L(G)$ has an even cycle decomposition of index 3.

Proof. We show that G has a perfect matching M whose cycle multigraph $\mathcal{C}(G, M)$ contains two cycles visiting an even number of odd cycle-vertices and spanning the whole set of odd cycle-vertices in $\mathcal{C}(G, M)$. By Theorem 4.0.8, the line graph $L(G)$ has an *ECD* of index 3.

In Figure 5.6 we represent two configurations of the superedge, that we call A and B , in which the bold edges define a perfect matching M^* of Y . The definition of M depends on the number r of copies of P_3 as follows.

Case 1: r is an even number. We choose for each block Q the sequence A, A, B, A, B, A for the superedges from left to right, so together with the bold edges of the base block in Figure 5.7 defines a perfect matching M of G .

The complementary 2-factor $G - M$ contains exactly two even cycles

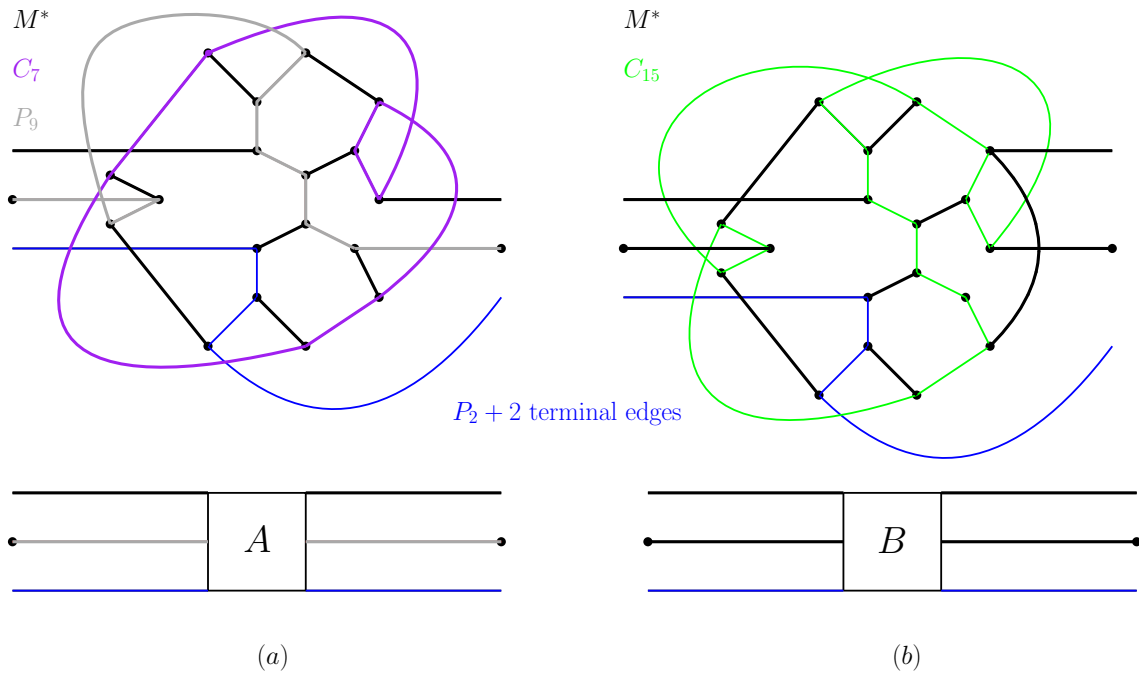

Figure 5.6: Two configurations of superedges, with M (bold edges in black) perfect matching.

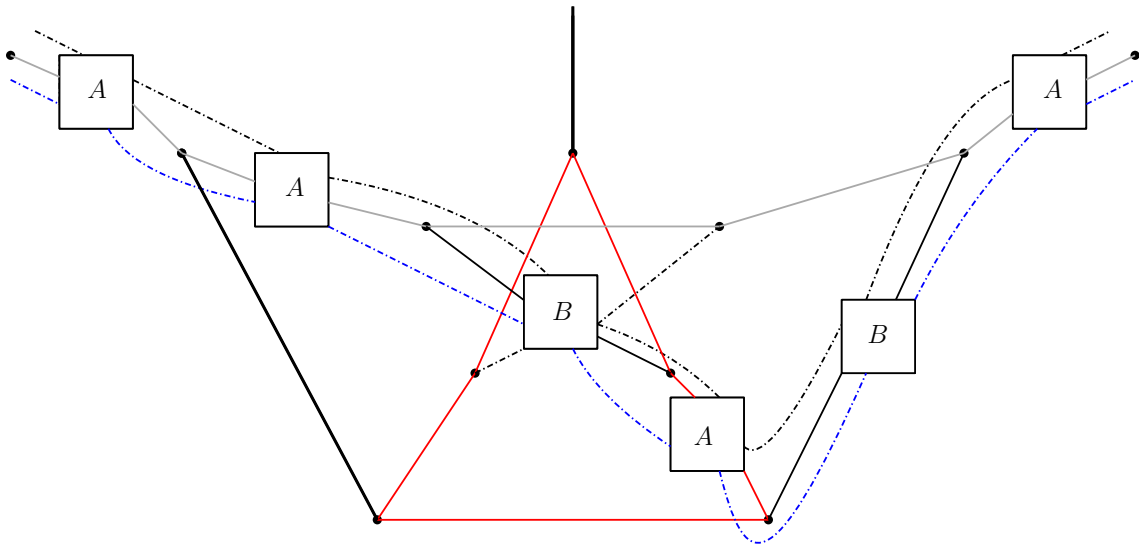

Figure 5.7: A configuration for an even number of Q blocks.

(blue and gray) which cross the entire graph and connect r odd cycles (C_{13} in Figure 5.7 in red) and exactly six odd cycles (C_7 and C_{15} of Figure 5.6 in purple and green, respectively) in each block Q . The cycle multigraph $\mathcal{C}(G, M)$ admits a partition of the odd cycle-vertices into two cycles, each of which contains an even number of odd cycle-vertices, see Figure 5.9. The existence of an even cycle decomposition of index 3 in $L(G)$ follows from Theorem 4.0.8.

Case 2: r is an odd number. The technique is similar to the proof of the even case, with a particular attention to the unique triad.

For the blocks Q , we define three new sequences of configurations A, B , from left to right in each superedge, that we call *Left*, *Right* and *Center*. These sequences, together with the bold edges in each block Q , provide a perfect matching M of G . The sequences are the following: *Left*: A, A, A, B, A, B , see Figure 5.10; *Right*: B, A, A, A, B, A , see Figure 5.11; *Center*: B, A, A, B, A, B , see Figure 5.12.

We take any two blocks of the triad and the block(s) between them opposite the triad, if any; we attribute counterclockwise the sequences *Left*, *Right*, *Center*, respectively, see for example the Figure 5.13 .

As for the remaining blocks, we match the vertices according to the sequences: A, A, B, A, B, A ; that we used for the case r even.

$G - M$ contains two odd cycles visiting (almost) all the blocks Q , see the blue and grey cycle in Figure 5.13. From each block Q , it also contains a red odd cycle, see Figures 5.10, 5.11, 5.12; and the cycles C_7, C_{15} in Figure 5.6 in each block Q . The cycle multigraph $\mathcal{C}(G, M)$ admits a partition of the odd cycle-vertices into two cycles, each of which contains an even number of odd cycle-vertices, see Figure 5.14. The existence of an even cycle decomposition of index 3 in $L(G)$ follows from Theorem 4.0.8.

■

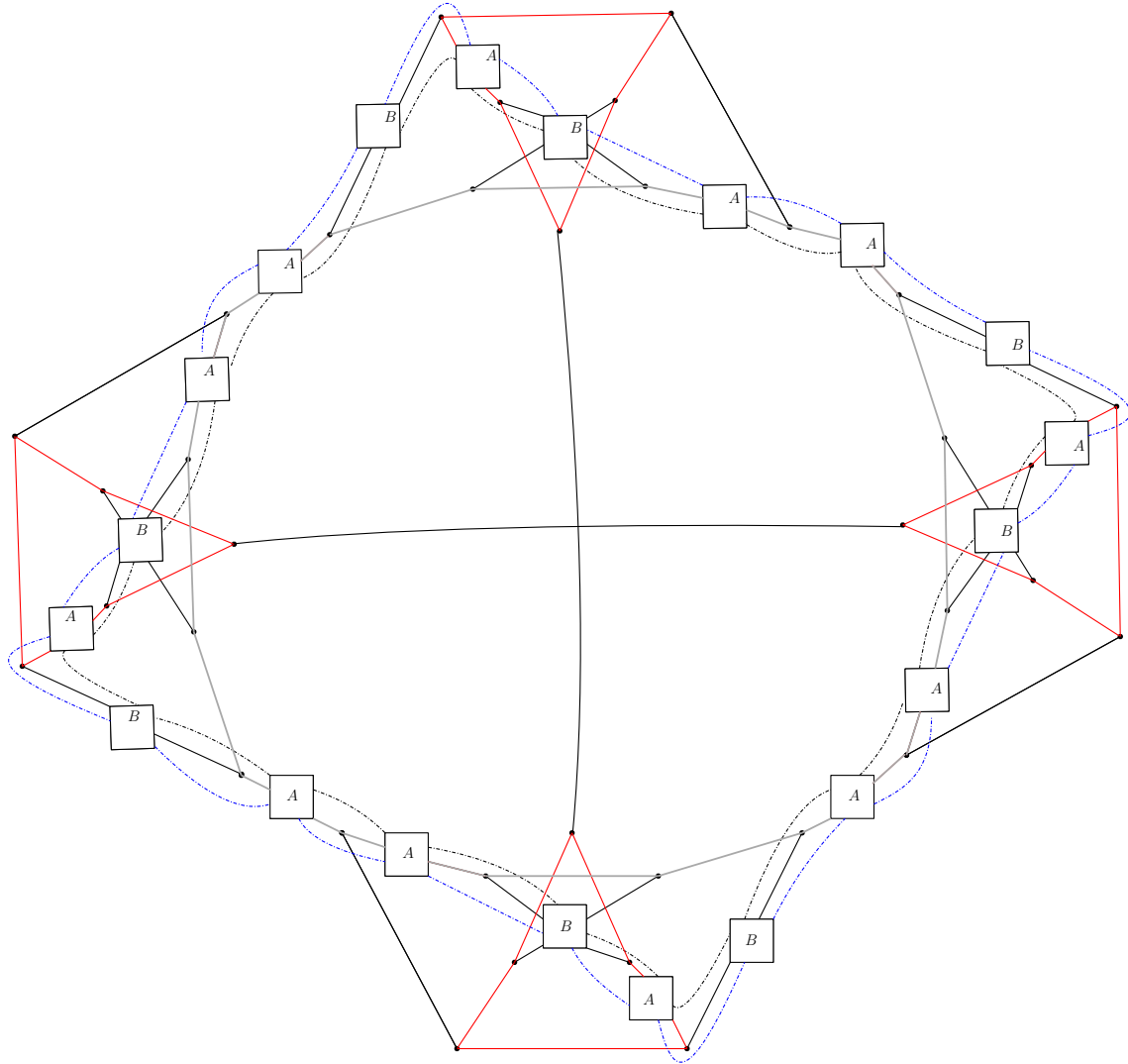

Figure 5.8: An example of class 2 cubic graph constructed in [22] by r copies of P_3 , r even; as proved in Proposition 5.0.3, the corresponding line graph has an *ECD* of index 3.

$\mathcal{C}(G, M)$

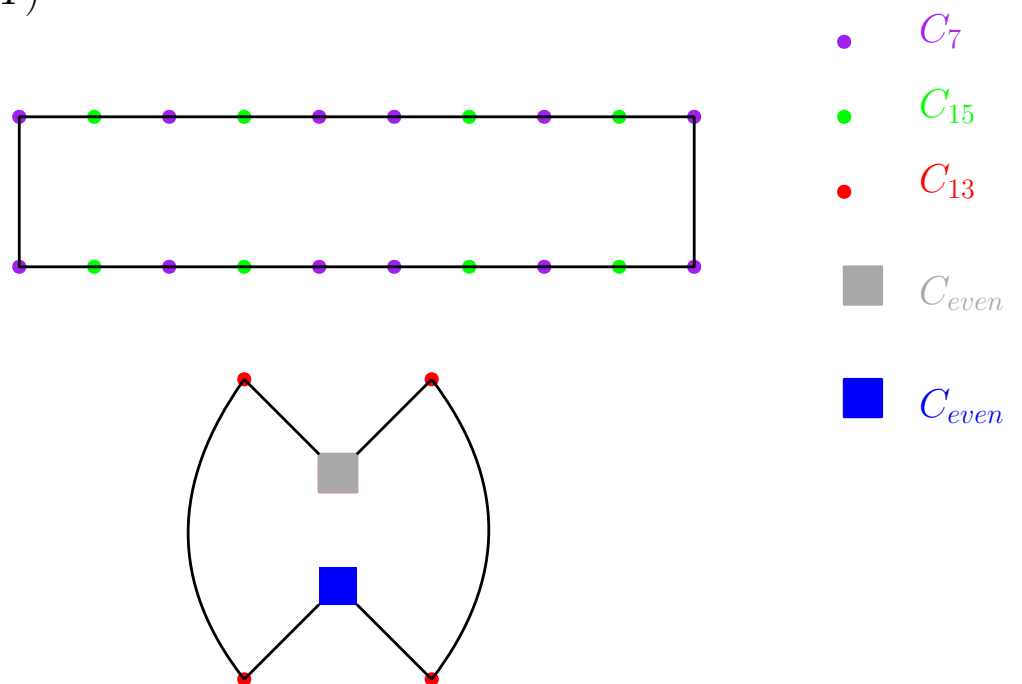

Figure 5.9: For the graph G in Figure 5.8, the proof of Proposition 5.0.3 defines a perfect matching M whose cycle multigraph $\mathcal{C}(G, M)$ has two cycles spanning the odd cycles-vertices; each cycle contains an even number of odd cycle-vertices.

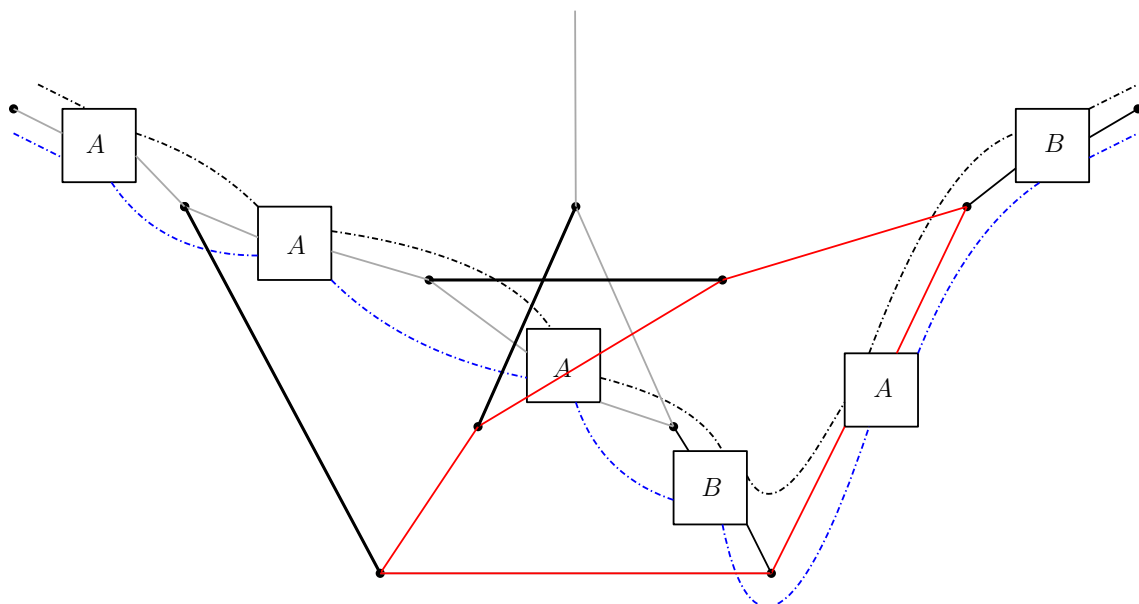

Figure 5.10: The Left sequence for an odd number of Q blocks.

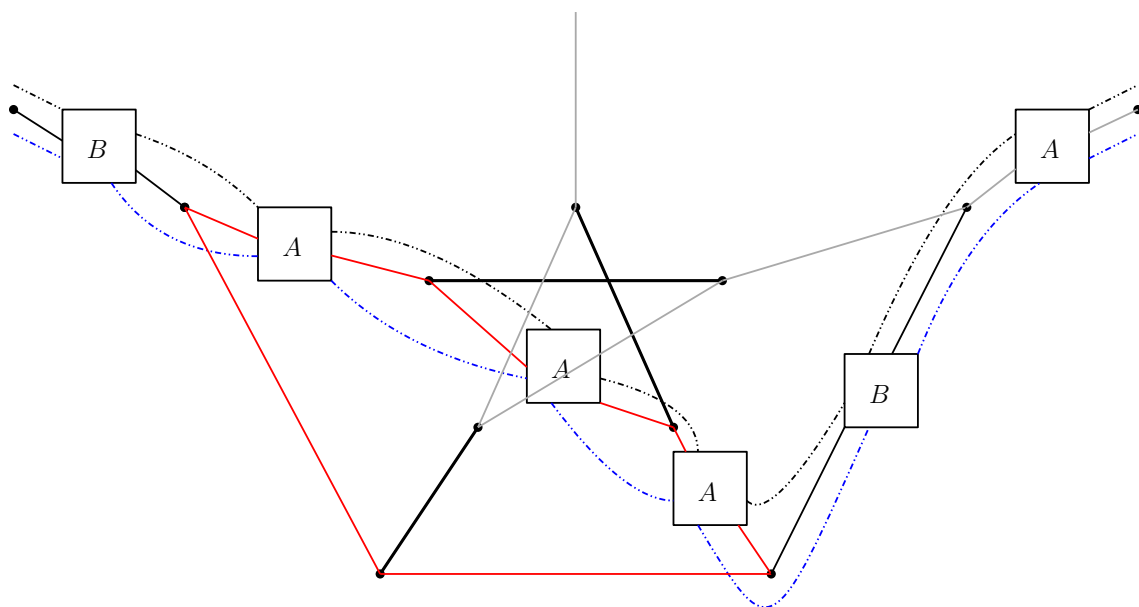

Figure 5.11: The Right sequence for an odd number of Q blocks.

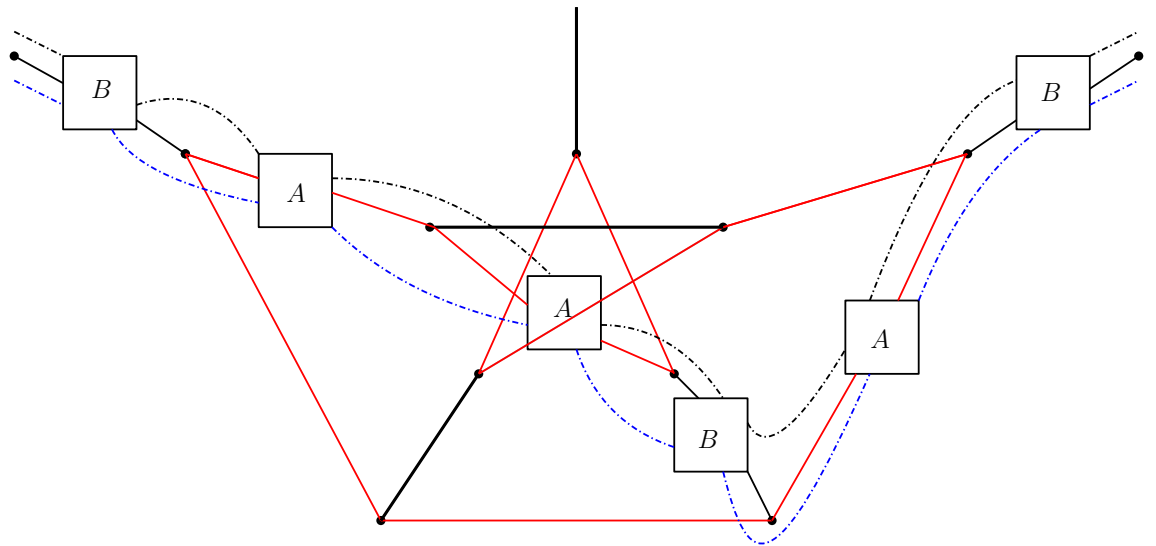

Figure 5.12: The Central sequence for an odd number of Q blocks.

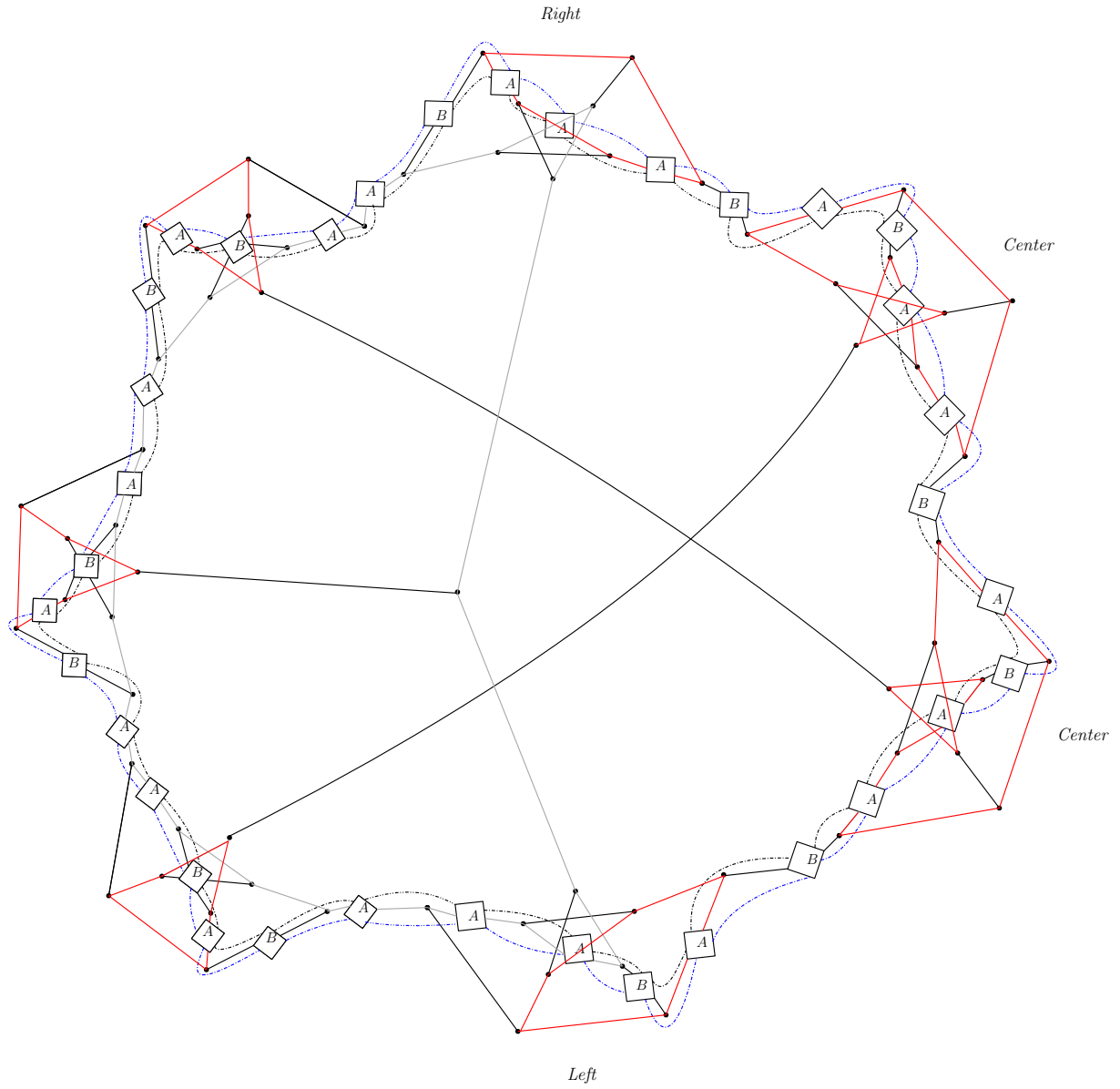

Figure 5.13: An example of class 2 cubic graph constructed in [22] by r copies of P_3 , r odd; as proved in Proposition 5.0.3, the corresponding line graph has an *ECD* of index 3.

$\mathcal{C}(G, M)$

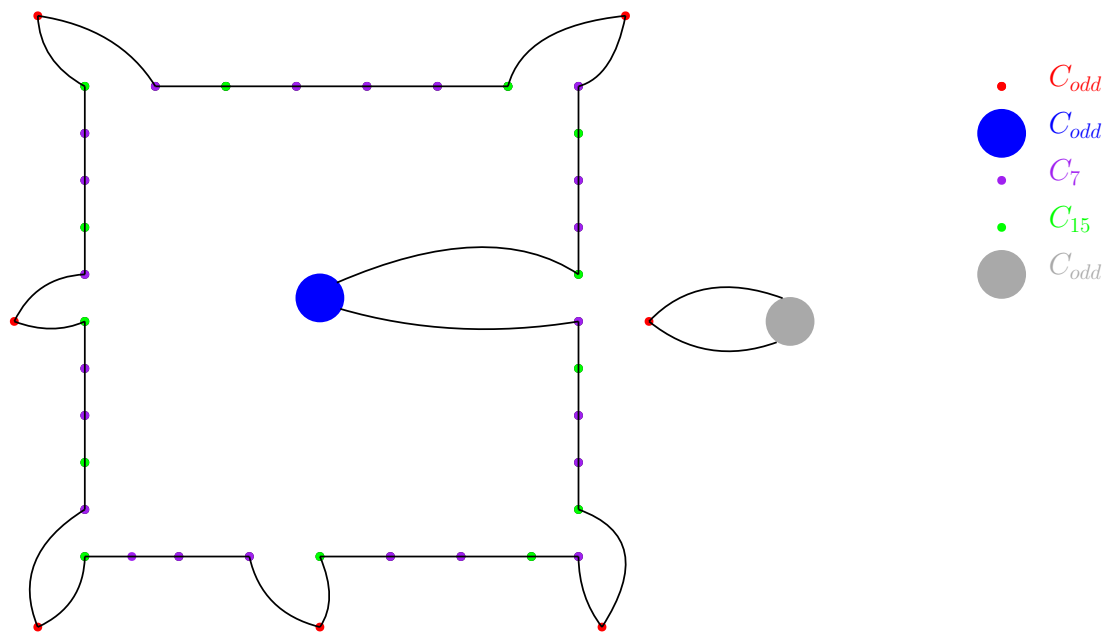

Figure 5.14: For the graph G in Figure 5.13, the proof of Proposition 5.0.3 defines a perfect matching M whose cycle multigraph $\mathcal{C}(G, M)$ has two cycles spanning the odd cycles-vertices; each cycle contains an even number of odd cycle-vertices.

Chapter 6

Final Remarks

The method in [8] of constructing an *ECD* of index 3 in the line graph of a cubic graph G is based on the existence of a cycle-multigraph $\mathcal{C}(G, M)$ whose odd cycle-vertices are partitioned into Eulerian subgraphs of maximum degree 4; each subgraph spans an even number of odd cycle-vertices and every odd cycle-vertex has degree 2. In the description given in Chapter 4, we consider the case of Eulerian subgraphs of maximum degree 2, since this case occurs for the line graph of cubic graphs with arbitrary large oddness that are considered in this thesis. The case of Eulerian subgraphs with maximum degree 4 occurs for the line graph of cubic graphs of oddness 2 that are not considered in this thesis. The method in [8] can be extended to cycle-multigraphs having Eulerian subgraphs of maximum degree larger than 4 and where the degree of an odd cycle-vertex might be larger than 2. This entails new definitions for the cycles in addition to the one in [8] of a fitting, junction and separating cycle. A generalization of the approach in [8] would prove the existence of an *ECD* of index 3 in the line graph of cubic graphs of oddness larger than 2 with a cycle-multigraph having a subgraph spanning the odd cycle-vertices and whose connected components are not limited to Eulerian subgraphs of maximum degree larger than 4.

A final remark about the existence of a 4-regular graph with every *ECDs* of index larger than 3 is in order. The results of this thesis and the possible

generalizations of the method in [8] suggest that it seems to be hard to find such a 4-regular graph in the family of 4-regular line graphs, actually in any family of 4-regular graphs. The non-existence would imply that the 4-regular graphs with palette index 4, 5 have no *ECD*, which would contribute to the problem on the existence of Eulerian graphs with no *ECD*, see for instance [17, 26].

Bibliography

- [1] M. Avesani, A. Bonisoli, G. Mazzuoccolo, *A family of multigraphs with large palette index*, Ars Math. Contemp. 17 (2019), 115-124.
- [2] G. Brinkmann, J. Goedgebeur, J. Hägglund, K. Markström, *Generation and properties of snarks*, J. Combin Theory Ser. B 103 (2013), 468-488.
- [3] J. A. Bondy, U.S.R. Murty, *Graph Theory*, Springer, (2008).
- [4] A. Bonisoli, S. Bonvicini, *Even cycles and even 2-factors in the line graph of a simple graph*, Electron. J. Combin. 24 (2017) P4.15.
- [5] A. Bonisoli, S. Bonvicini, G. Mazzuoccolo, *On the Palette Index of a Graph: The Case of Trees*, Lect. Notes Semin. Interdiscip. Mat. 14 (2017), 49–55.
- [6] S. Bonvicini, M.M. Ferrari, *On the minimum number of bond-edge types and tile types: An approach by edge-colorings of graphs*, Discrete Appl. Math. 227 (2020), 1-13.
- [7] S. Bonvicini, G. Mazzuoccolo, *Edge-colorings of 4-regular graphs with the minimum number of palettes*, Graphs Combin. 32 (2016), 1293–1311.
- [8] S. Bonvicini, M.C. Molinari, *Even Cycle Decompositions of index 3 by a novel coloring technique*, submitted.
- [9] C.J. Casselgren, P.A. Petrosyan, *Some results on the palette index of graphs*, Discrete Math. Theor. Comput. Sci. 21(3) (2019), dmtcs: 4509.

BIBLIOGRAPHY

- [10] H. Fleischner, *(Some of) the many uses of Eulerian graphs in graph theory (plus some applications)*, Discrete Math. 230 (2001), 23–43.
- [11] A.V. Ghazaryan, *On palette index of unicycle and bicycle graphs*, Proceedings of the YSU A: Physical and Mathematical Sciences 53 (2019), 3-12.
- [12] J. Hägglund, *On snarks that are far from being 3-edge-colorable*, Electron. J. Combin. 23(2) (2016), P2.6.
- [13] I. Holyer, *The NP-completeness of edge-coloring*, SIAM J. Comput. 10(4), (1981), 718-720.
- [14] M. Horňák, J. Hudák, *On the palette index of complete bipartite graphs*, Discuss. Math. Graph Theory 38(2) (2018), 463-476.
- [15] M. Horňák, R. Kalinowski, M. Meszka, M. Woźniak, *Minimum number of palettes in edge colorings*, Graphs Combin. 30 (2014), 619–626.
- [16] A. Huck, M. Kochol, *Five cycle double covers of some cubic graphs*, J. Combin. Theory Ser. B 64 (1995) 119-125.
- [17] B. Jackson, *On circuit covers, circuit decompositions and Euler tours of graphs*, London Math. Soc. Lecture Note Ser., 187, Cambridge Univ. Press, Cambridge, (1993), 191–210.
- [18] F. Jaeger, *A survey of the cycle double cover conjecture*, Ann. Discrete Math. 27 (1985), 1-12.
- [19] J. H. Kim, N.C. Wormald, *Random matchings which induce Hamilton cycles and Hamiltonian decompositions of random regular graphs*, J. Combin. Theory Ser. B 81(1) (2001) 20–44.
- [20] M. Kochol, *Superposition and constructions of graphs without nowhere-zero k -flows*, European J. Combin. 23 (2002), 281–306.

BIBLIOGRAPHY

- [21] W. Liu, H.You, Q. Cui, *On even cycle decompositions of line graphs of cubic graphs*, Discrete Math. 343 (2020), 111904.
- [22] R. Lukot'ka, E.Máčajová, J. Mazák, M. Škoviera, *Small snarks with large oddness*, Electron. J. Combin. 22(1) (2015), P1.51.
- [23] K. Markström, *Complete minors in cubic graphs with few short cycles and random cubic graphs*, Ars Combin. 70 (2004) 289–295.
- [24] K. Markström, *Even cycle decompositions of 4-regular graphs and line graphs*, Discrete Math. 312 (2012) 2676–2681.
- [25] J. Petersen. *Die Theorie der regulären Graphen*. Acta Math. 15 (1891), 193–220.
- [26] R. Rizzi, *On 4-connected graphs without even cycle decompositions*, Discrete Math. 234 (1–3) (2001) 181–186.
- [27] P.D. Seymour, *Even circuits in planar graphs*, J. Combin. Theory Ser. B 31 (3) (1981) 327–338.
- [28] K.S. Smbatyan, *Two results on the palette index of a graphs*, Proceedings of the YSU A: Physical and Mathematical Sciences 55 (2021), 36-43.
- [29] C. Thomassen, *Reflections on graph theory*, J. Graph Theory 10 (3) (1986), 309–324.
- [30] O. Veblen, *An application of modular equations in analysis situs*, Ann. of Math. (2) 14(1) (1912), 86-94.
- [31] V. Vizing, *On an estimate of the chromatic class of a p-graph*, Diskret. Analiz. 3 (1964), 9-17.
- [32] C.Q. Zhang, *On even circuit decompositions of Eulerian graphs*, J. Graph Theory 18(1) (1994), 51–57.